



SKYMI RR

BE AMAZED

2026

Antenna Catalog

skymirr.com

- **Cellular 3G/4G/5G Antennas and Modules**
 - TAMP114: 4G LTE/5G Wideband Omni Antenna 3
 - TAMP 141: 4G LTE/5G Ultra Broadband Omni Antenna. 4
 - TAMP125: 4G LTE/5G Compact Broadband MIMO Antenna Module 5
 - TAMP161: 4G LTE/5G MIMO Broadband High Performing Antenna Module. 7
 - TAMP154: High Gain Broadband 4G/5G MIMO Directional Antenna Module 11
 - TAEP162: 4G LTE / 5G Compact Broadband Chip Antenna 16
 - TAMP172: LTE Omni Antenna with Magnetic Mount 21
 - TAMP173: LTE Low Profile Antenna with Screw Mount 22
- **WiFi Antennas**
 - TAEP121: WiFi Triple Band FPCB Antenna. 23
 - TAMP118: WiFi 6e/7 External Antenna. 24
 - TAMP169: Single feed Multi-band Chip Antenna. 26
 - TAMP159: Wi-Fi 6e/7 External Antenna. 30
 - TAMP156: WiFi Directional Antenna 32
- **FPCB Antennas**
 - TAEP134: 4G LTE/5G Sub6 and GNSS L1 Ultra-Broadband FPCB Antenna 34
 - TAEP132: 4G/5G & GNSS-L5 Ultra-Broadband FPCB Antenna 35
 - TAEP 131: 4G LTE/5G Ultra-Broadband FPCB Antenna 36
 - TAEP133: 4G 4G/5G Broadband FPCB Antenna 37
 - TAEP135: WiFi 6e/7 Triple Band FPCB Antenna. 38
- **Embedded (Monitoring) Antenna**
 - MAEP103: Ultra-Small NFC Antenna 39
- **GNSS Antenna**
 - CGMP 165 : GPS and GLONASS SMD Antenna 40
 - CGMP 166 : GPS and GLONASS Patch Antenna 43
 - CGMP 167 : GPS and GLONASS Ceramic Patch Antenna 46
 - CGMP 168 : Single feed Multi-band Patch Antenna 49
 - CGMA 174 : GPS/GNSS Antenna with Magnet and LNA 52
 - CGMA 175 : GPS/GNSS Antenna with LNA 53
- **Customized Antenna**
 - Customized Antenna 54
- **About SkyMirr 55**

Cellular Antenna

INTRODUCTION

The TAMP 114 is a compact high-efficiency 4G/5G cellular antenna engineered for reliable MIMO performance in mobile and fixed applications.

Its low-profile design and optimized isolation deliver strong signal integrity in space-constrained and high-interference environments.

APPLICATION

Ideal for fleet telematics, industrial IoT gateways, enterprise routers, and cellular failover applications. The TAMP114 supports mobile and fixed installations requiring dependable connectivity, stable throughput, and consistent performance across challenging RF environments.

Features and Benefits

- External Antenna without Hinge
- Covering Key 4G/5G Sub6 Bands
- Antenna Size : 125.5 x Φ 13mm
- Connector : SMA (male)
- Color : Black / White
- Operating Frequency Bands
 - 824~960MHz
 - 1710~2170MHz
 - 2500~2690MHz
- High Efficiency up to 80%
- Peak Gain: 1.1 ~ 3.8 dBi
- 50 ohm / SMA male connector
- RoHS compliance



Performance

Gain and Efficiency

Frequency [Mhz]	Low Band				Mid/High Band					
	824	880	894	960	1710	1880	1920	2170	2500	2690
Efficiency [%]	64.4	66.5	75.7	77.9	46.4	64.0	56.9	41.3	53.3	61.6
Peak Gain [dBi]	1.11	1.51	2.21	2.09	2.65	3.87	3.06	1.30	1.97	2.76
Impedance	50 Ω									
Polarization	Vertical									
Directivity	Omni Directional									

VSWR

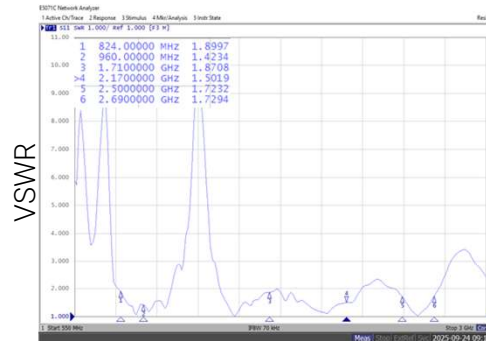

Radiation Pattern

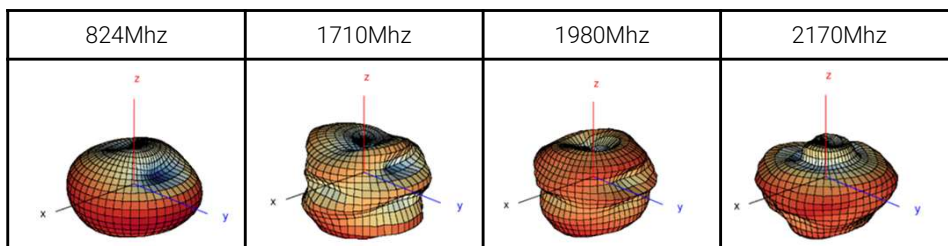

Dimension (unit: mm)

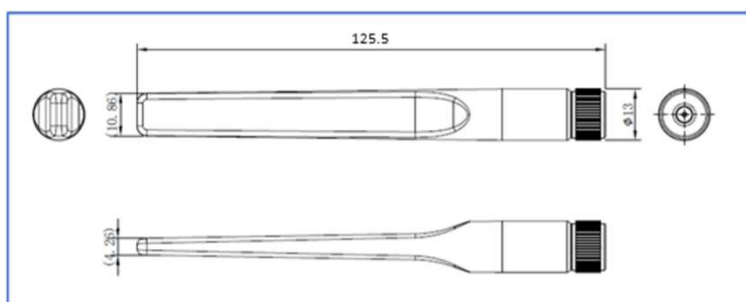

Contact Details:

US: +1-3213931039

TW: +886-963383713

KR: +82-1047149824

IN: +91-9967297130

Email: sales@skymirr.com

Website: www.skymirr.com

Cellular Antenna

INTRODUCTION

The TAMP141 is an ultra wideband omnidirectional external antenna with high performance, covering the entire 4G LTE and 5G Sub6 frequency bands. It can be used for connecting wireless communication devices such as Consumer Premise Equipment (CPE) or various IoT applications, sensors, trackers, and smart devices to the mobile network.

APPLICATION

Any wireless device using 4G and/or 5G Sub6 frequency bands operating in any region throughout the world.

The TAMP141 performs especially well in the lower 600 MHz bands where newer sub6 5G bands operate.

Example Uses – Wireless Routers, Gateways, CPEs, Automotive devices, IoT devices, etc.

Contact Details:

US: +1-3213931039

TW: +886-963383713

KR: +82-1047149824

IN: +91-9967297130

Email: sales@skymirr.com

Website: www.skymirr.com

Features and Benefits

- **External Antenna with Hinge Covering All 4G/5G Sub6 Bands with high Performance**
- Antenna Size: 196.32 mm x 36 mm x Φ 13 mm
- Connector : SMA (male)
- Color : Black / White
- Operating Frequency Bands
 - 617~960MHz
 - 1447~2690MHz
 - 3300~5925MHz
- High Efficiency up to 82%
- Peak Gain: 2.1~ 6.4 dBi
- RoHS Compliance



Performance

Gain and Efficiency

Frequency [MHz]	617	960	1447	2170	2305	2690	3300	4200	5000	5925
Efficiency [%]	57.7	77.2	72.8	82.2	70.8	77.5	75.3	76.3	77.5	66.0
Peak Gain [dBi]	2.12	3.23	2.90	2.24	1.82	2.07	6.41	2.99	3.76	4.16
Impedance	50 Ω									
Polarization	Vertical									
Directivity	Omnidirectional									

VSWR

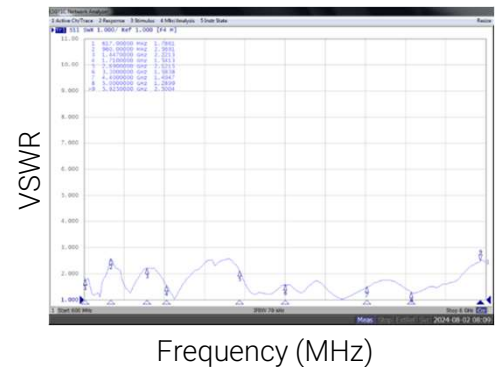

Radiation Pattern

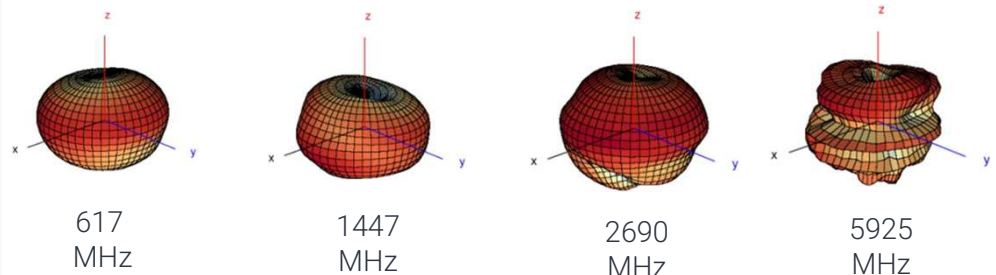

Dimension (unit: mm)

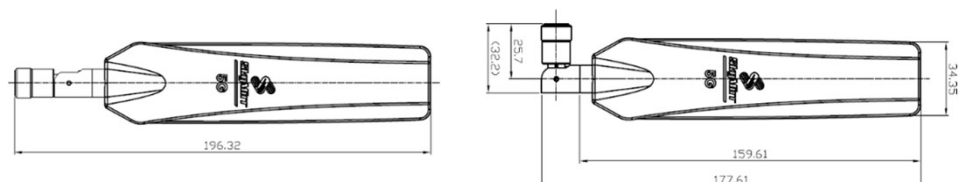

TAMP125

4G LTE/5G Compact Broadband MIMO Antenna Module

Features and Benefits

- MIMO Antenna Module Covering ALL 4G LTE and 5G Sub 6 Bands
- Antenna Size: 125 mm x 80 mm x 22 mm (not including Cable and Connector)
- Connector: SMA
- RF Cable Length: 1.5M
- Operating Frequency Bands
 - 600~960MHz
 - 1710~2170MHz
 - 2500~2690MHz
 - 3300~6000MHz
- Supports 4x4 MIMO at 1710~6000MHz
- Supports 2x2 MIMO at 600~960MHz
- High Peak Gain up to 3.3 dBi
- High Efficiency up to 53%
- RoHS Compliance



INTRODUCTION

The TAMP125 is a small MIMO antenna module supporting entire 4G LTE and 5G sub6 bands, including the very low 600 MHz band, with good gain and isolation.

It supports 2x2 MIMO at the low bands and 4x4 MIMO in mid/high bands. It can be used for advanced wireless communication devices or systems.

APPLICATION

Any 4G/5G wireless device or system that requires MIMO coverage with good gain and isolation. Ideal for external / remote antenna installations.

Examples – Home networking, Logistic, Automotives, Routers, Gateways, CPEs, and more IoT devices.

Performance

Gain and Isolation

	Frequency [Mhz]	Low Band				Mid/High Band				Ultra High Band									
		617	699	746	824	960	1710	1850	2170	2360	2496	2690	3300	3600	3800	4200	4400	5000	5925
Efficiency	5G Main-Ant1	33.5	48.1	41.3	53.1	46.3	31.9	28.1	39.6	38.1	46.6	46.3	53.5	50.4	37.3	38.0	33.2	30.3	45.6
	5G AUX-Ant3						29.4	31.4	30.6	36.1	36.5	37.8	42.9	45.9	33.0	35.1	32.0	26.7	30.3
	5G AUX-Ant4						29.1	31.6	28.3	31.3	33.2	35.5	39.6	42.8	28.8	32.7	30.1	26.0	29.0
	5G Main-Ant2	33.5	49.6	51.0	52.1	40.6	35.4	31.6	45.4	38.5	47.9	46.5	53.1	49.2	38.5	39.4	31.8	32.0	44.5
	Average	33.5	48.8	46.1	52.6	43.5	31.5	30.7	36.0	36.0	41.0	41.5	47.3	47.1	34.4	36.3	31.8	28.7	37.3
Peak Gain	5G Main-Ant1	-0.75	1.36	-0.18	1.14	1.00	-0.76	-0.93	-0.51	0.43	1.18	0.83	0.67	0.94	-0.33	1.37	1.31	1.00	3.36
	5G AUX-Ant3						-2.51	-1.99	-1.62	-0.07	-0.94	-0.14	2.01	1.56	0.77	-0.09	-0.75	0.07	-0.03
	5G AUX-Ant4						-2.22	-1.99	-1.72	-1.19	-0.52	-0.93	1.99	1.03	0.66	-0.22	-0.61	-0.22	-0.55
	5G Main-Ant2	-0.35	0.48	0.42	-0.06	-0.08	-0.73	-0.63	0.54	0.46	1.07	1.45	0.61	1.03	0.20	1.41	1.23	1.14	2.91
	Average	-0.55	0.92	0.12	0.54	0.46	-1.55	-1.38	-0.83	-0.09	0.20	0.30	1.32	1.14	0.32	0.62	0.30	0.50	1.42

SWR



Isolation Between Ports



Contact Details:

US: +1-3213931039

TW: +886-963383713

KR: +82-1047149824

IN: +91-9967297130

Email: sales@skymirr.com

Website: www.skymirr.com

TAMP125

4G LTE/5G Compact Broadband MIMO Antenna Module

Cellular Antenna

Radiation Pattern

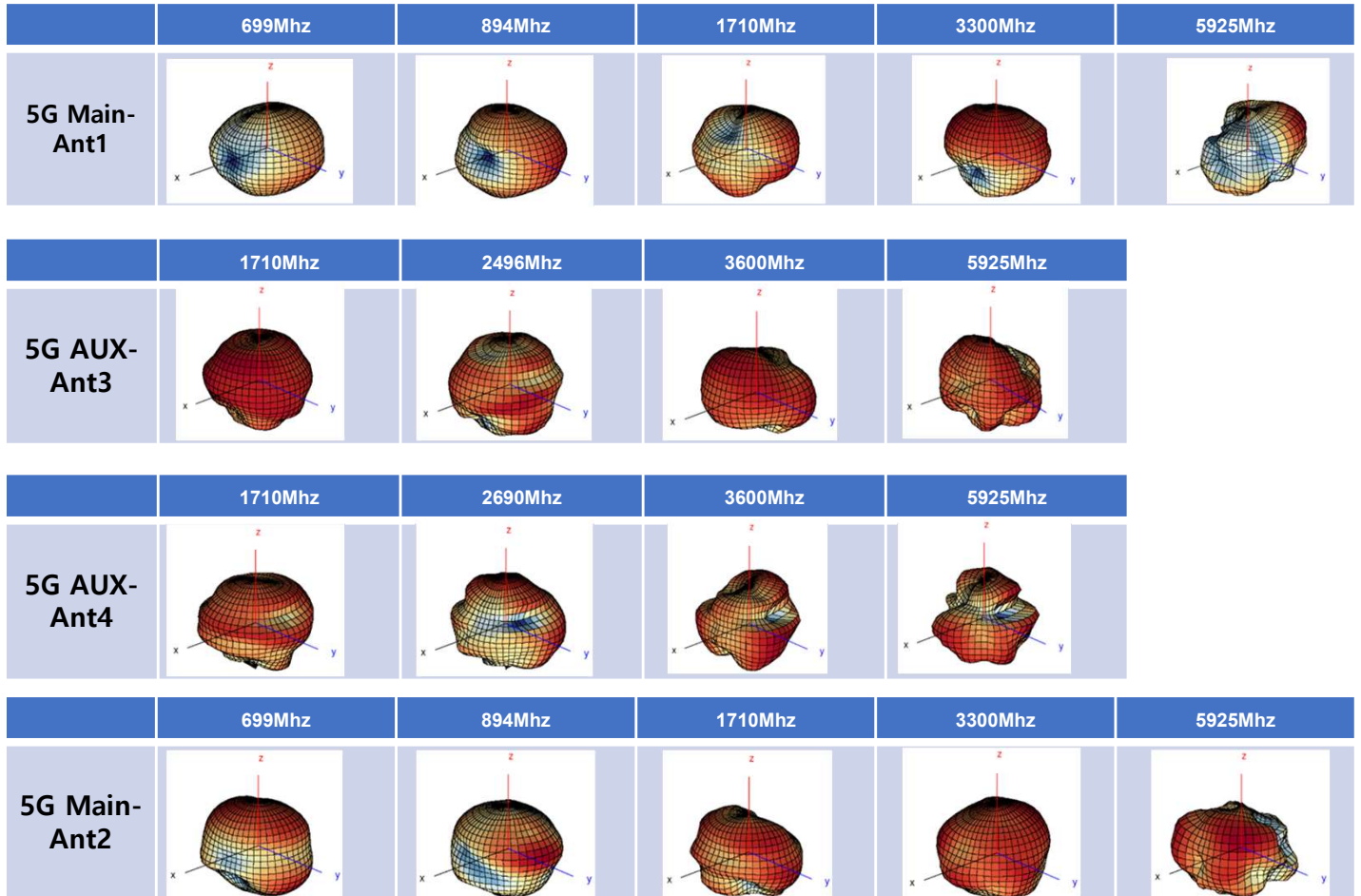

Dimension (unit: mm)

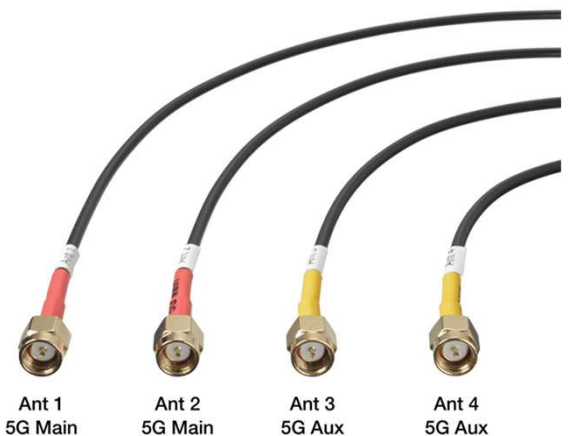
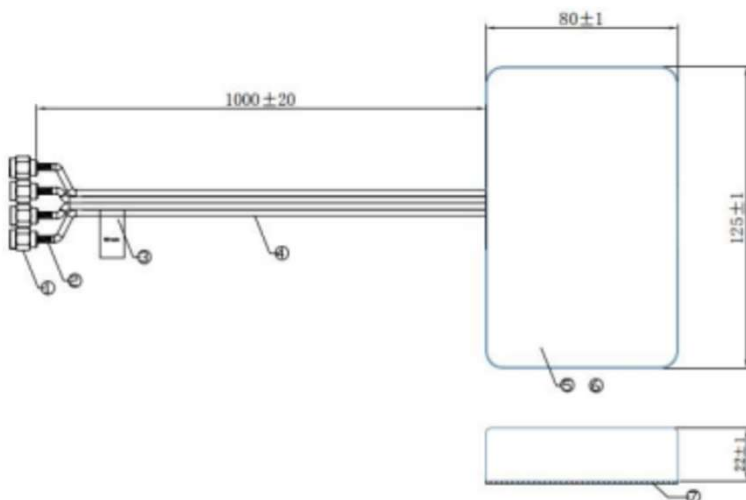

TAMP161

4G LTE / 5G MIMO Broadband High Performing Antenna Module

Features and Benefits

- **High Efficiency MIMO Antenna Module Covering ALL 4G LTE and 5G Sub 6 Bands**
- **Operating frequency**
Ant 1: 5G Main (617 ~ 5925MHz), White
Ant 2: 5G Aux (1710 ~ 5925MHz), Red
Ant 3: 5G Aux (1710 ~ 5925MHz), Red
Ant 4: 5G Main (617 ~ 5925MHz), White
- Supports 4x4 MIMO at 1710~6000MHz
- Supports 2x2 MIMO at 600~960MHz
- High Peak Gain up to 6 dBi
- High Efficiency up to 90%
- RoHS Compliance
- Antenna Size: 190 x 140 x 22.5 mm
- Cable length: 0.5m
- Connector: SMA (male)

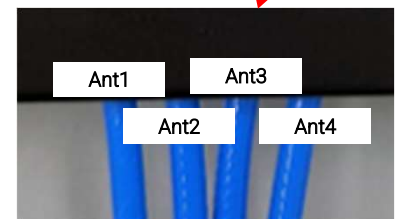

Antenna information

INTRODUCTION

The TAMP161 is a MIMO antenna module supporting entire 4G LTE and 5G sub6 bands, including the very low 600 MHz band, with high radiation performance and isolation.

It supports 2x2 MIMO at the low bands and 4x4 MIMO in mid/high bands. It can be used for advanced wireless communication devices or systems.

APPLICATION

The TAMP161 is ideal for 4G/5G routers, gateways, and connected devices requiring stable, wideband MIMO performance.

Common applications include enterprise and home networking, industrial IoT, logistics and asset tracking, transportation systems, and CPE deployments. Designed for indoor use, it provides dependable connectivity wherever strong, multi-band RF performance is required.

Performance

VSWR

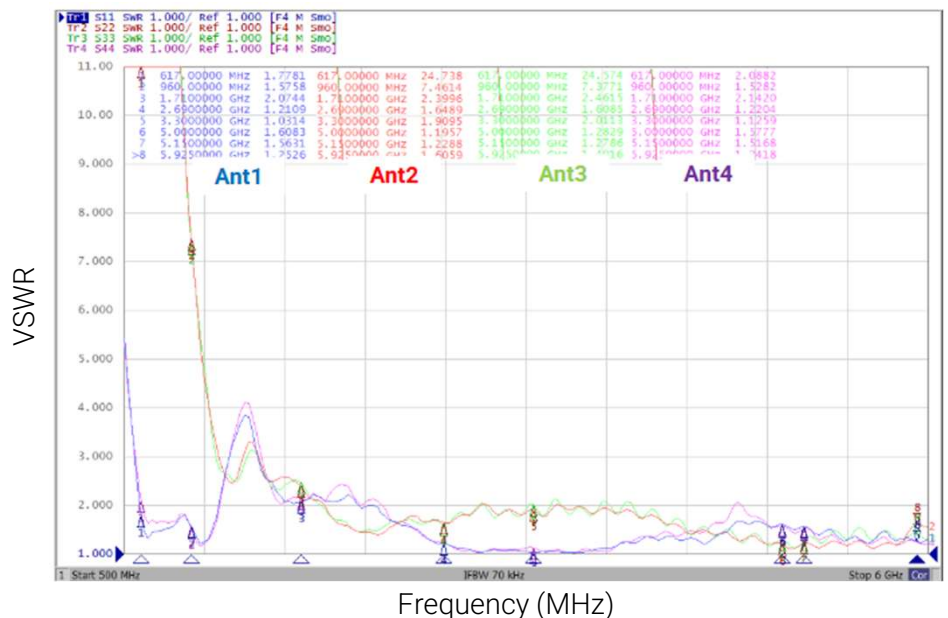

Efficiency

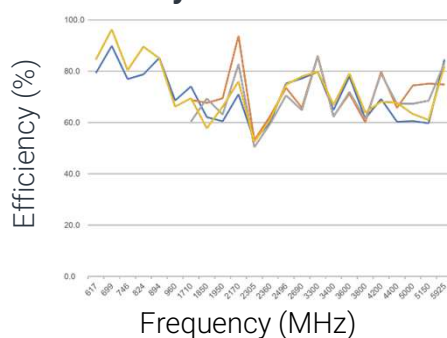

Peak Gain

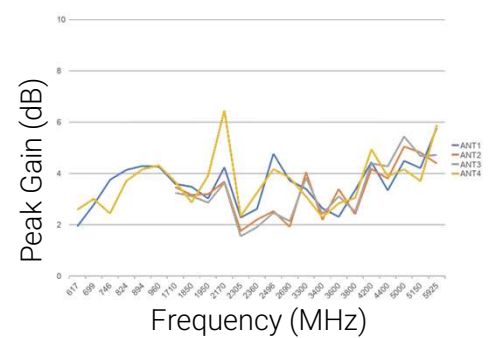

Contact Details:

US: +1-3213931039

TW: +886-963383713

KR: +82-1047149824

IN: +91-9967297130

Email: sales@skymirr.com

Website: www.skymirr.com

Antenna Isolation

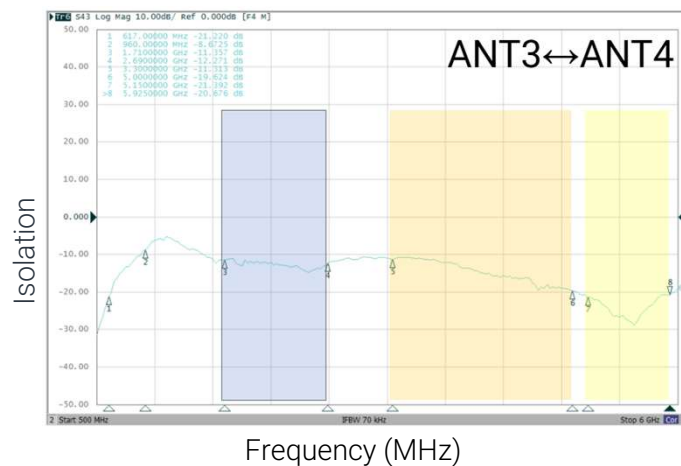
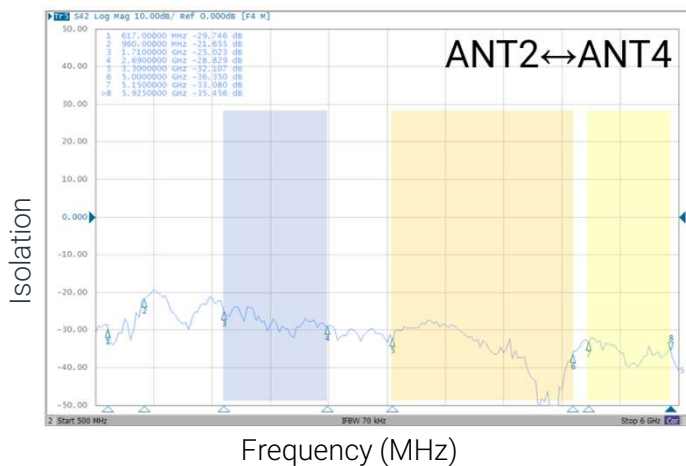
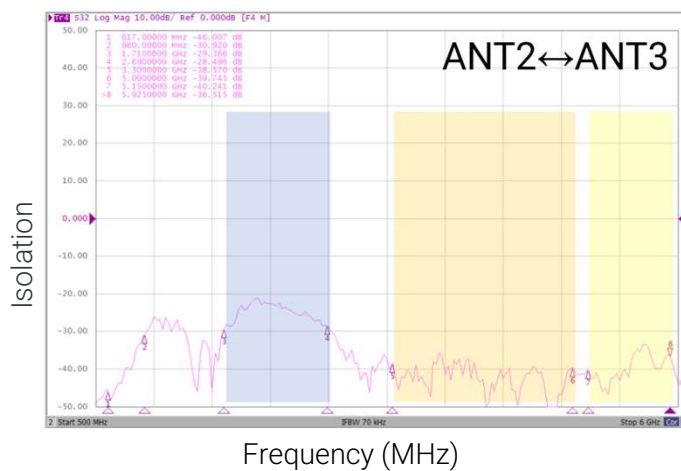
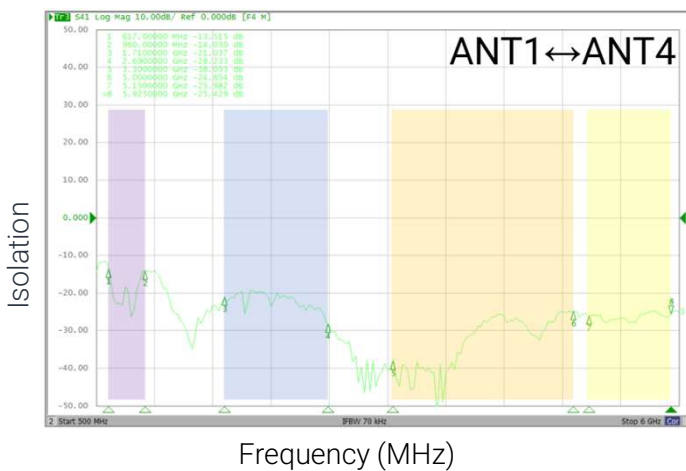
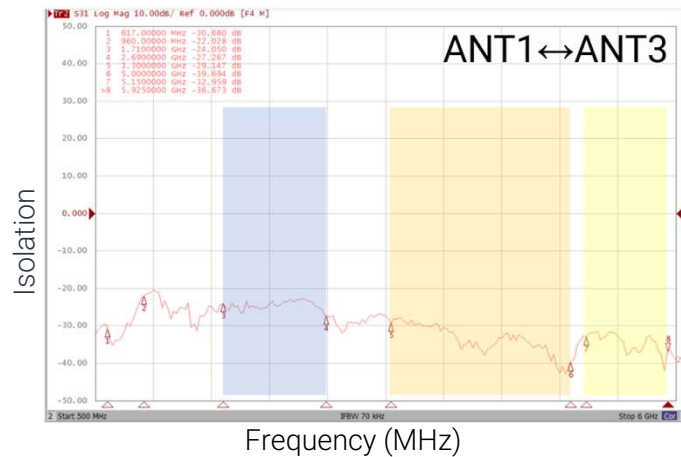
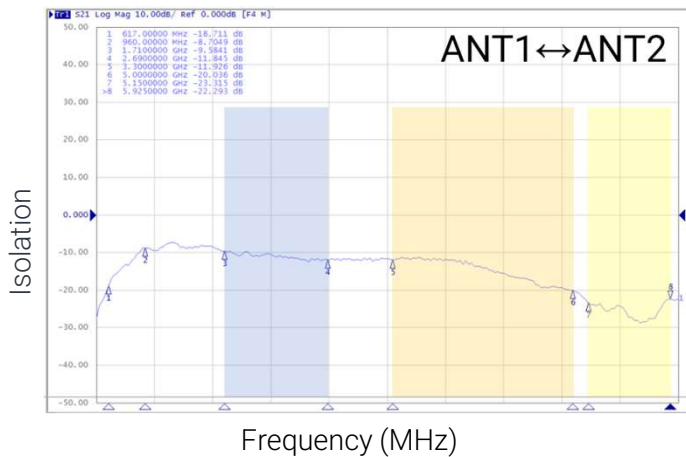

Radiation Patterns

Radiation Pattern ANT_1

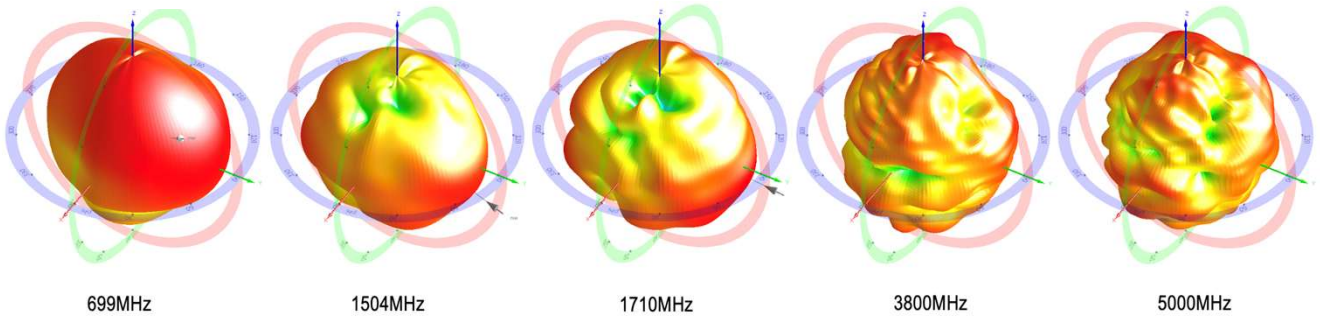

Radiation Pattern ANT_4

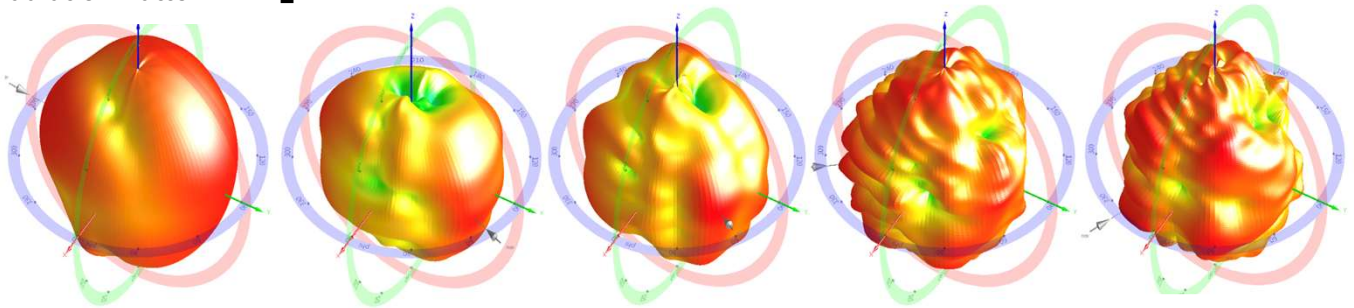

Radiation Pattern ANT_2

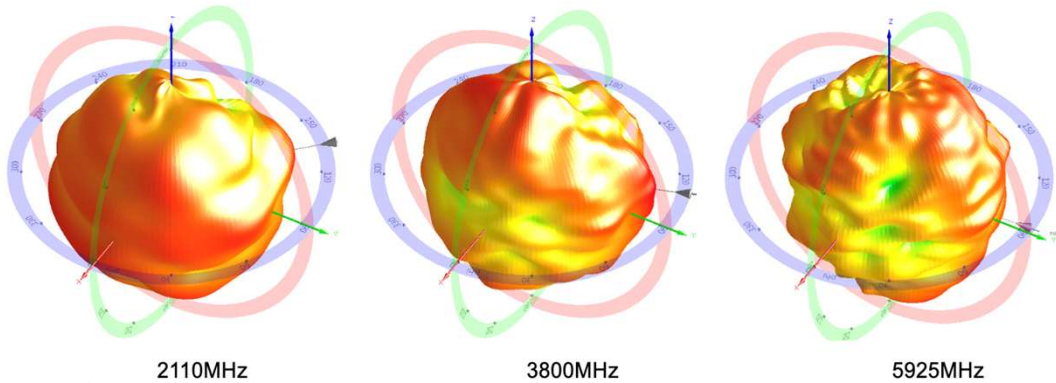

Radiation Pattern ANT_3

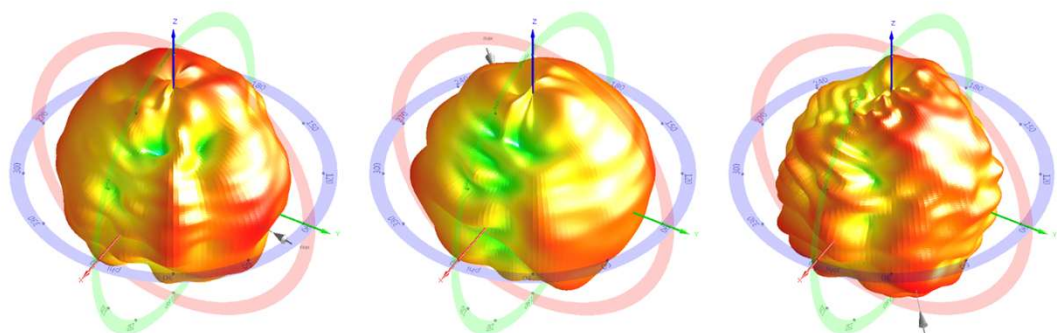

Peak Gain/Efficiency

ANT 1	Frequency [MHz]	617	699	746	824	894	960
	Efficiency [%]	79.3	89.9	77.0	78.8	85.2	68.6
	Peak Gain [dBi]	1.9	2.8	3.8	4.1	4.3	4.3

ANT 1	Frequency [MHz]	1710	1850	1950	2170	2305	2360	2496	2690	3300	3400	3600	3800	4200	4400	5000	5150	5925
	Efficiency [%]	74.1	62.1	60.5	71.0	52.9	60.3	75.2	77.2	79.8	64.9	77.9	61.5	69.2	60.3	60.6	59.7	84.5
	Peak Gain [dBi]	3.6	3.5	3.0	4.2	2.3	2.6	4.8	3.7	3.4	2.6	2.3	3.3	4.4	3.3	4.5	4.2	5.8

ANT 2	Frequency [MHz]	1710	1850	1920	2170	2305	2360	2496	2690	3300	3400	3600	3800	4200	4400	5000	5150	5925
	Efficiency [%]	68.8	67.7	69.4	93.8	53.1	62.6	73.5	65.8	86.0	62.5	71.2	60.1	79.8	65.7	74.4	75.2	74.8
	Peak Gain [dBi]	3.5	3.2	3.2	3.7	1.8	2.2	2.5	1.9	4.1	2.2	3.4	2.4	4.2	3.8	5.1	4.8	4.4

ANT 3	Frequency [MHz]	1710	1850	1920	2170	2305	2360	2496	2690	3300	3400	3600	3800	4200	4400	5000	5150	5925
	Efficiency [%]	60.4	69.3	63.1	82.8	50.4	59.5	70.6	64.8	85.7	62.3	72.0	61.2	79.0	67.4	67.3	68.5	83.3
	Peak Gain [dBi]	3.2	3.1	2.9	3.6	1.6	1.9	2.5	2.1	3.8	2.4	3.1	2.5	4.4	4.3	5.4	4.7	4.7

ANT 4	Frequency [MHz]	617	699	746	824	894	960
	Efficiency [%]	84.6	96.3	80.4	89.6	85.0	66.2
	Peak Gain [dBi]	2.6	3.0	2.4	3.7	4.2	4.3

ANT 4	Frequency [MHz]	1710	1850	1950	2170	2305	2360	2496	2690	3300	3400	3600	3800	4200	4400	5000	5150	5925
	Efficiency [%]	69.5	57.8	66.2	76.0	52.5	61.2	74.7	77.9	79.9	66.9	79.2	63.9	68.2	67.7	63.3	61.0	82.1
	Peak Gain [dBi]	3.7	2.9	3.9	6.5	2.3	3.3	4.2	3.8	3.1	2.3	2.8	3.0	4.9	3.9	4.2	3.7	5.9

LMR195 Cable loss

Frequency	Loss for 1m cable [dB]	Loss for 2m cable [dB]
617MHz	-0.33	-0.61
960MHz	-0.42	-0.77
1710MHz	-0.55	-1.05
2690MHz	-0.71	-1.34
3300MHz	-0.84	-1.54
5000MHz	-1.03	-1.95
5150MHz	-1.07	-2.04
5925MHz	-1.11	-2.12

Cable Length: 0.5m (Option with 1m and 2m additional cable)

Dimension (unit: mm)

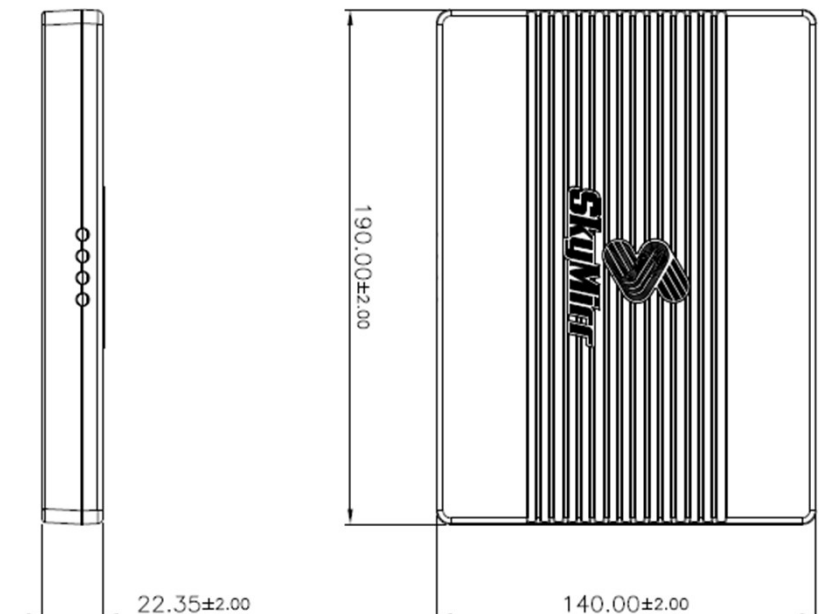

TAMP154

High Gain Broadband 4G/5G MIMO Directional Antenna Module

Features and Benefits

- **High Gain Antenna Module Covering 4G LTE and 5G Sub 6 Bands**
- Broadband 4x4 MIMO Panel Antenna
Connector: SMA (Female),
Optional Cable: 1m, 3m, 6m with
SMA (Male) Connector
- Operating Frequency Bands
– 600~6000MHz
- High Peak Gain up to 9.5 dBi



INTRODUCTION

The TAMP154 is an advanced wireless communication component designed to transmit and receive multiple data streams simultaneously, significantly enhancing signal strength, data throughput, and connection reliability.

With its directional gain capabilities, this type of antenna focuses radio frequency energy in specific directions, reducing interference and extending range significantly for FWA installations.

APPLICATION

Any cellular wireless device that requires a high gain antenna covering 4G LTE and 5G Sub6 frequency bands.

Example Uses – Routers, Gateways, CPEs, Automotive devices, IoT devices, etc

Performance

Electrical				
Frequency Range	617-960 MHz	1710-2690 MHz	3300-5000 MHz	5150-5925 MHz
Gain (Peak)	4.6~6.7 dBi	6.1~9.4 dBi	6.5~9.7 dBi	6.3~8.7 dBi
VSWR	≤3.0	≤3.0	≤3.3	≤2.8
Isolation	≤20dB	≤25dB	≤25dB	≤25dB
Efficiency	60~90%	55~85%	50~80%	60~70%
Input Impedance	50Ω			
Antenna Type	Directional			
Power Rating	20 W			

Physical		Extension RF Cable Attenuation (per 1m)	
Radome Color	Pantone blue	617MHz	-0.33
Dimensions (w x h x d) Antenna only	450 x 330.0 x 63.15 mm	960MHz	-0.42
Connector	SMA-female	1710MHz	-0.55
Extension cable Length	1m, 3m and 6m (SMA male to SMA male)	2690MHz	-0.71
Weight	3.0 ± 0.1 kg	3300MHz	-0.84
		5000MHz	-1.03
		5150MHz	-1.07
		5925MHz	-1.11

Peak Gain

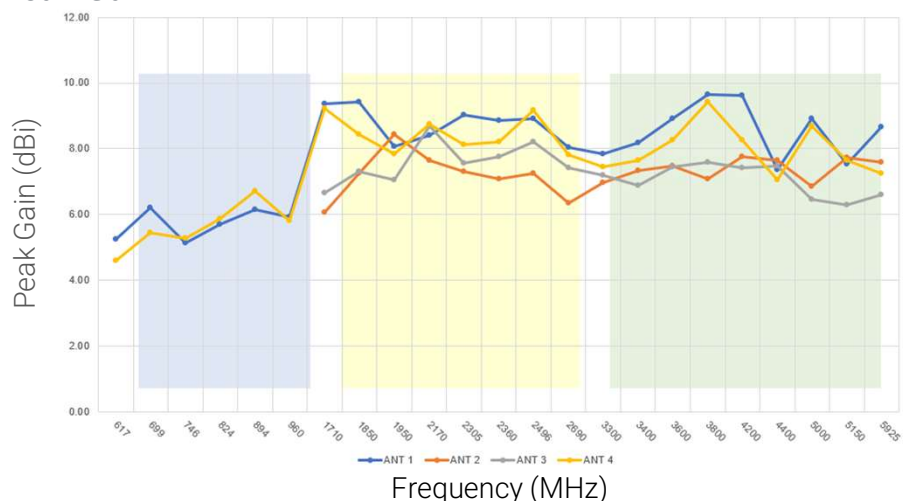

Contact Details:

US: +1-3213931039

TW: +886-963383713

KR: +82-1047149824

IN: +91-9967297130

Email: sales@skymirr.com

Website: www.skymirr.com

VSWR

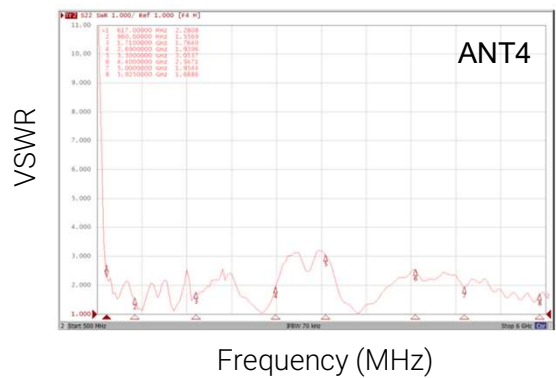
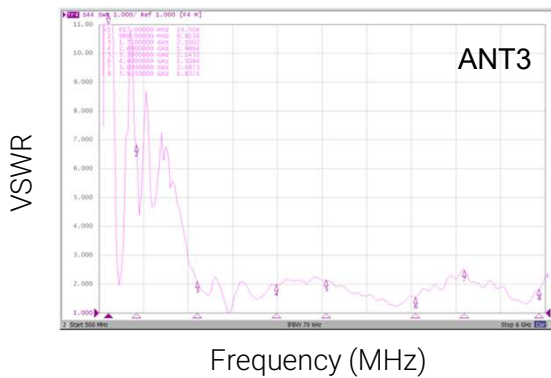
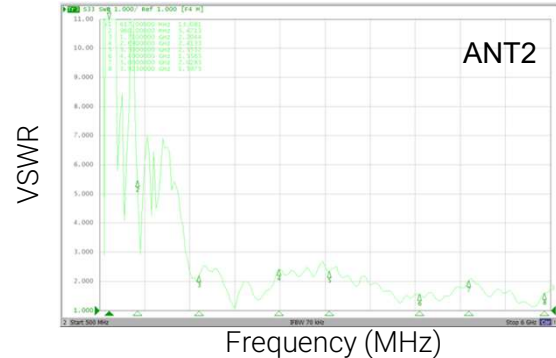
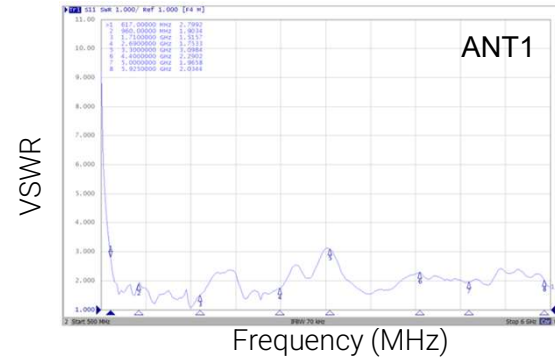

Peak Gain/ Efficiency

	Frequency [MHz]	617	699	746	824	894	960	1447	1463	1496	1511
ANT 1	Efficiency [%]	60.4	71.6	59.6	63.4	92.8	82.7	79.1	78.1	79.3	75.4
	Peak Gain [dBi]	5.2	6.2	5.1	5.7	6.2	5.9	6.7	6.7	6.5	6.2

	Frequency [MHz]	1710	1850	1950	2170	2305	2360	2496	2690	3300	3400	3600	3800	4200	4400	5000	5150	5925
ANT 1	Efficiency [%]	79.8	81.5	70.9	75.4	81.3	81.9	86.1	78.7	60.9	61.9	73.5	76.6	65.9	54.0	68.1	60.9	67.1
	Peak Gain [dBi]	9.4	9.4	8.1	8.4	9.0	8.9	8.9	8.1	7.9	8.2	8.9	9.7	9.6	7.4	8.9	7.5	8.7

	Frequency [MHz]	1710	1850	1920	2170	2305	2360	2496	2690	3300	3400	3600	3800	4200	4400	5000	5150	5925
ANT 2	Efficiency [%]	70.8	75.1	73	86.9	73.4	76.4	83.4	76.6	67.7	69.4	71.8	71.1	83.1	81.9	70.6	70.8	62.9
	Peak Gain [dBi]	6.1	7.3	8.5	7.7	7.3	7.1	7.2	6.3	7.0	7.3	7.5	7.1	7.8	7.7	6.9	7.7	7.6

	Frequency [MHz]	1710	1850	1920	2170	2305	2360	2496	2690	3300	3400	3600	3800	4200	4400	5000	5150	5925
ANT 3	Efficiency [%]	65.4	80.9	72.0	83.0	72.16	73.7	78.5	77.5	70.6	72.2	75.3	76.7	80.3	78.5	61.3	66.0	59.7
	Peak Gain [dBi]	6.7	7.3	7.1	8.7	7.6	7.8	8.2	7.4	7.2	6.9	7.4	7.6	7.4	7.5	6.5	6.3	6.6

	Frequency [MHz]	617	699	746	824	894	960	1447	1463	1496	1511
ANT 4	Efficiency [%]	70.9	67.5	73.1	69.2	82.5	81.3	73.9	71.0	71.1	66.6
	Peak Gain [dBi]	4.6	5.4	5.3	5.9	6.7	5.8	6.5	6.4	6.2	6.5

	Frequency [MHz]	1710	1850	1950	2170	2305	2360	2496	2690	3300	3400	3600	3800	4200	4400	5000	5150	5925
ANT 4	Efficiency [%]	71.0	67.5	54.9	74.0	79.0	79.7	81.5	66.1	51.5	57.5	76.4	74.6	60.5	43.2	66.8	59.7	64.7
	Peak Gain [dBi]	9.2	8.5	7.8	8.8	8.1	8.2	9.2	7.8	7.5	7.6	8.3	9.4	8.3	6.6	8.7	7.7	7.3

Isolation

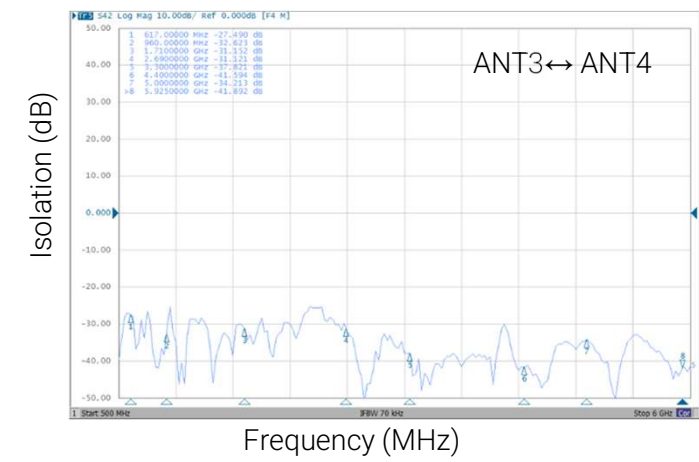
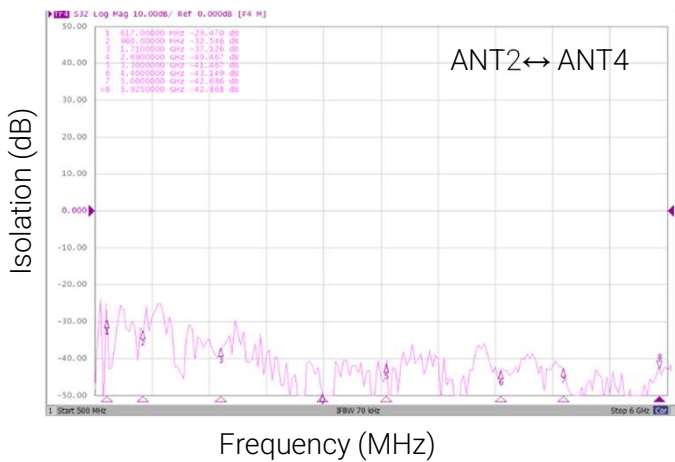
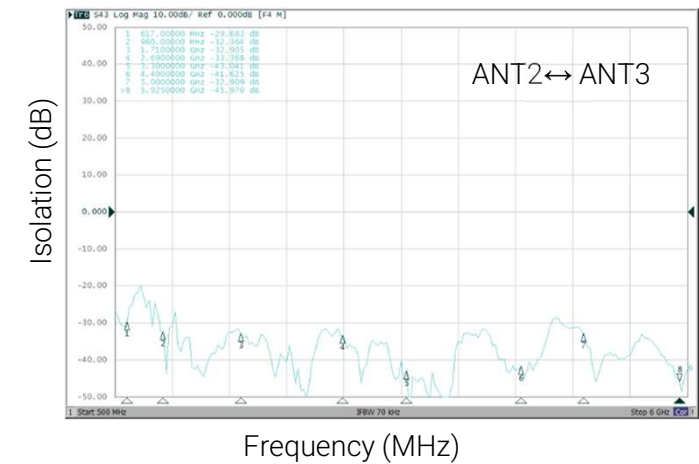
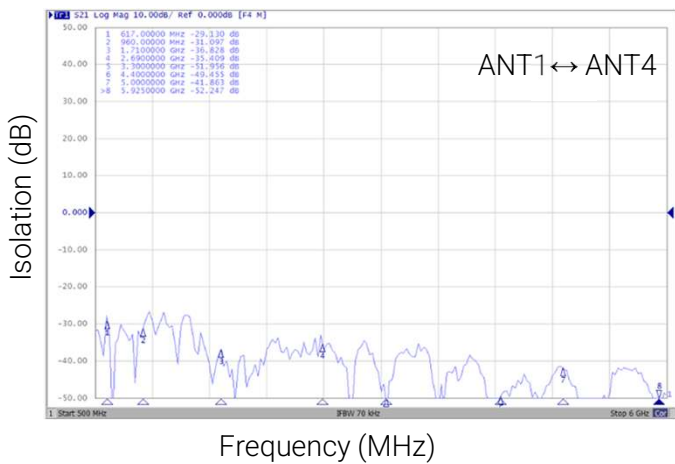
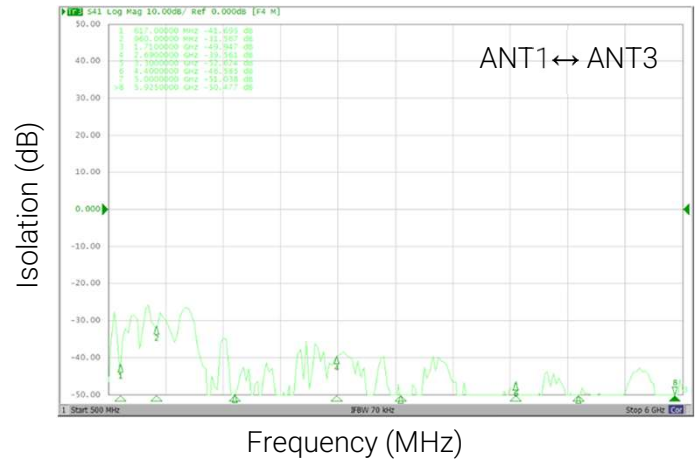
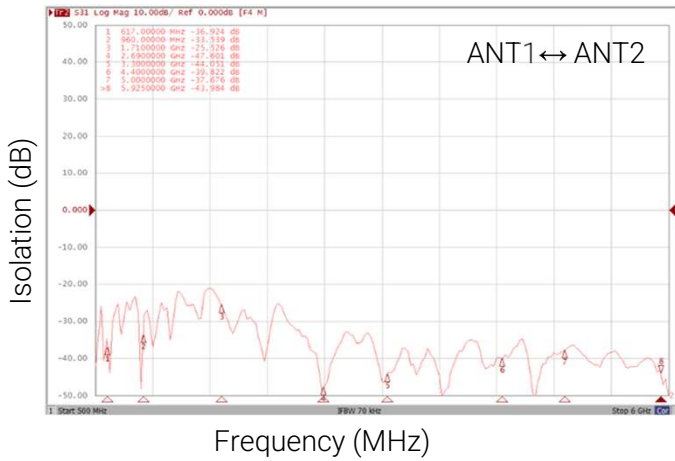

Radiation Direction

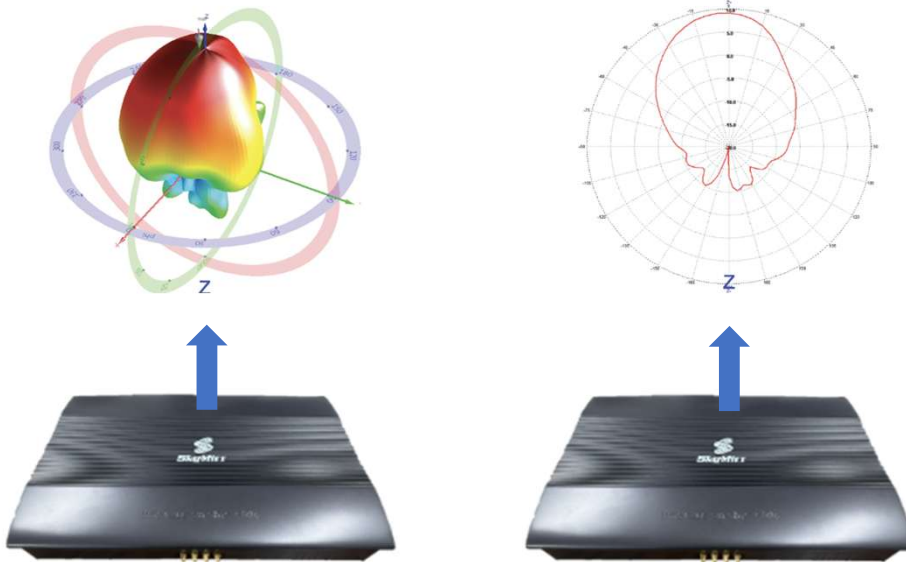

Radiation Pattern

Radiation Pattern_ANT1

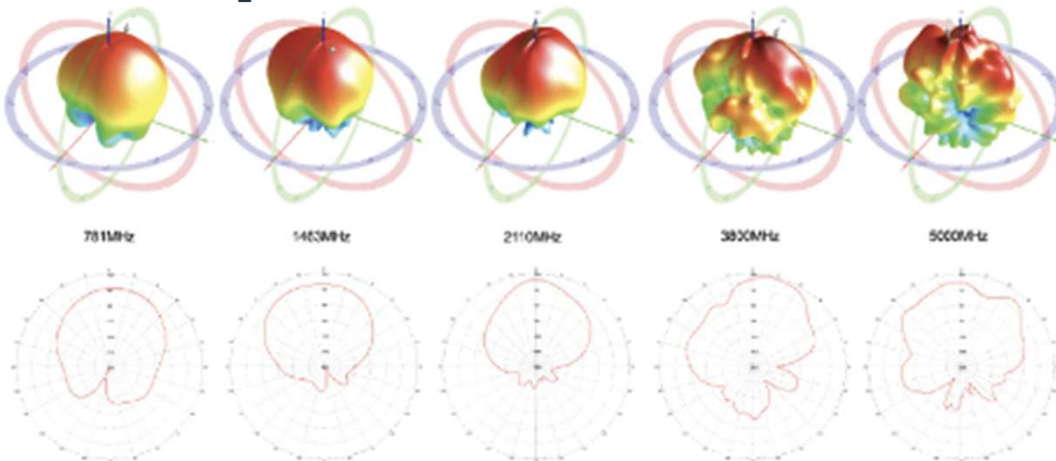

Radiation Pattern_ANT2

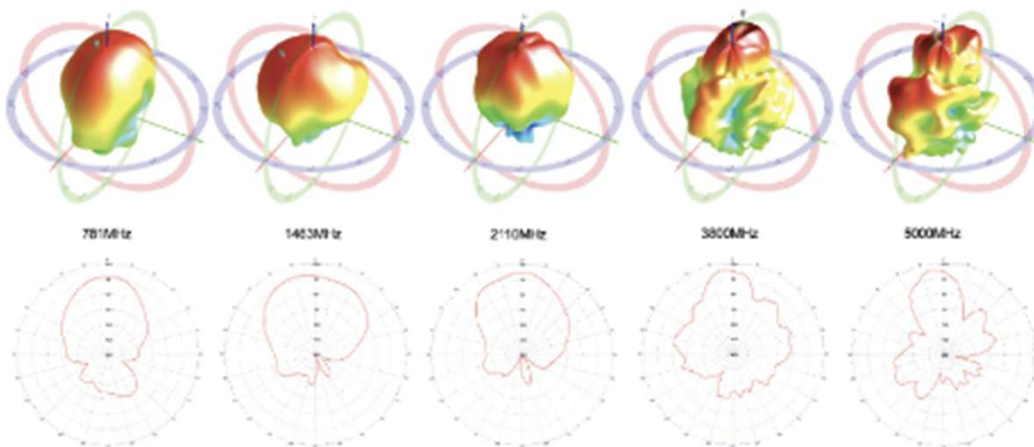

Radiation Pattern

Radiation Pattern_ANT3

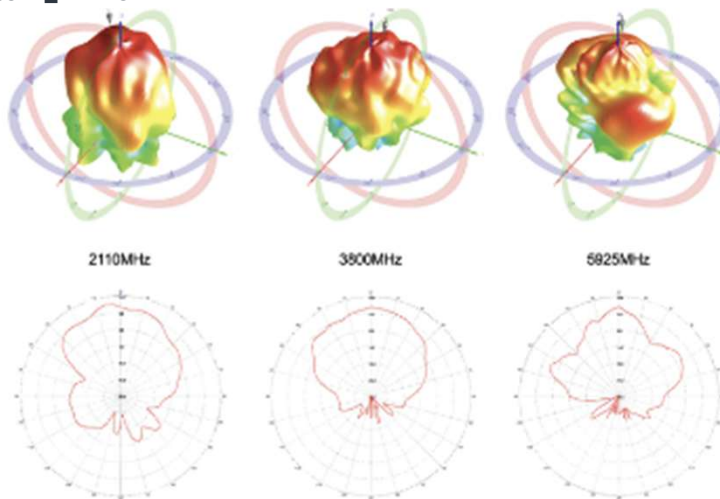

Radiation Pattern_ANT4

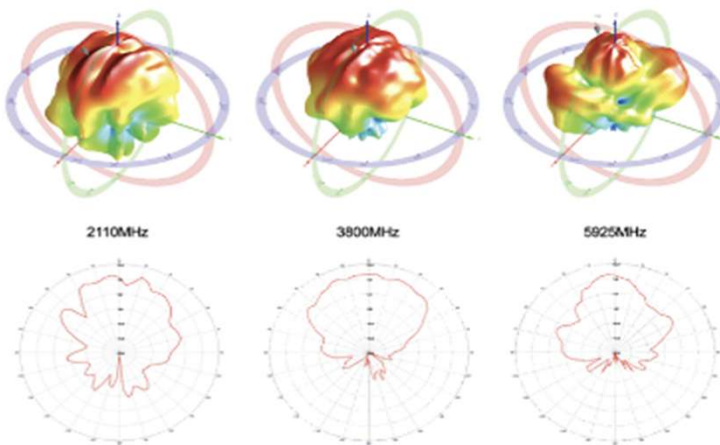

Dimension (unit: mm)

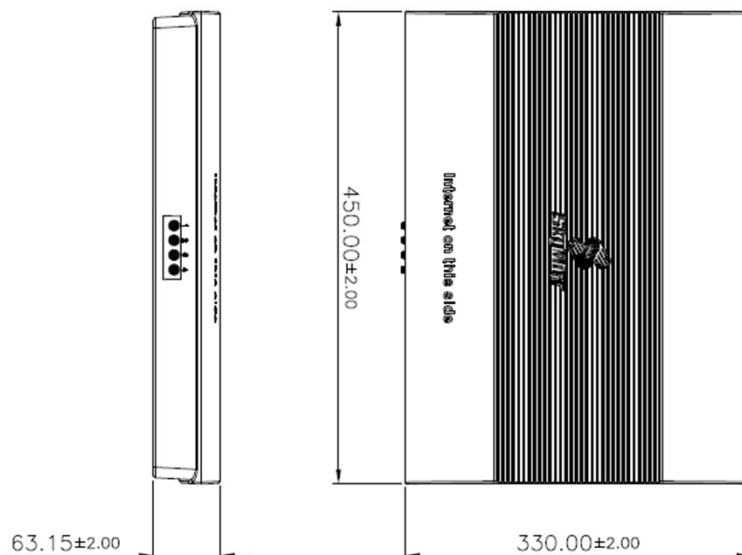

Cellular Antenna

INTRODUCTION

The TAEP162 is a surface mount compact chip style antenna with high performance covering LTE bands from 600 to 2700 MHz.

It can be directly mounted to the PCBA of any wireless communication device for various applications.



APPLICATION

TAEP162 provides a solution for applications where cost and space must be minimized.

The antenna is mounted to the same PCB assembly that holds the radio and other system components.

The PCB must include a ground filled region that will act as the counterpoise for the antenna.

Features and Benefits

- Surface Mount Part
- **Size:** 45mm x 9 mm x 1.6mm
- **Weight:** 1.2 grams
- **Color:** Black
- **Operating Frequency Bands:** 617~960MHz, 1710~2690MHz
- **Efficiency** up to 90%
- **Peak Gain:** -2.3 ~ 3.6 dBi
- **Impedance:** 50 Ω
- **Polarization:** Vertical
- **Directivity:** Omnidirectional
- **Operating Temperature Range:** -40°C to +85°C

Performance

GAIN AND EFFICIENCY†

Frequency [MHz]	617	960	1710	2155	2690
Efficiency [%]	35	66	38	90	53
Peak Gain [dBi]	-2.3	1.3	0.5	3.6	1.1

†Measured on TAEPEVK Evaluation Kit

VSWR

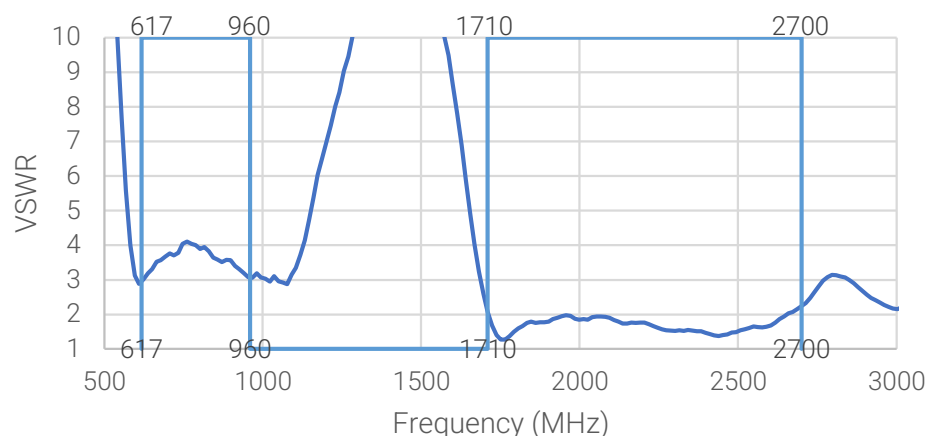

Contact Details:

US: +1-3213931039

TW: +886-963383713

KR: +82-1047149824

IN: +91-9967297130

Email: sales@skymirr.com

Website: www.skymirr.com

Cellular Antenna

Radiation Patterns†

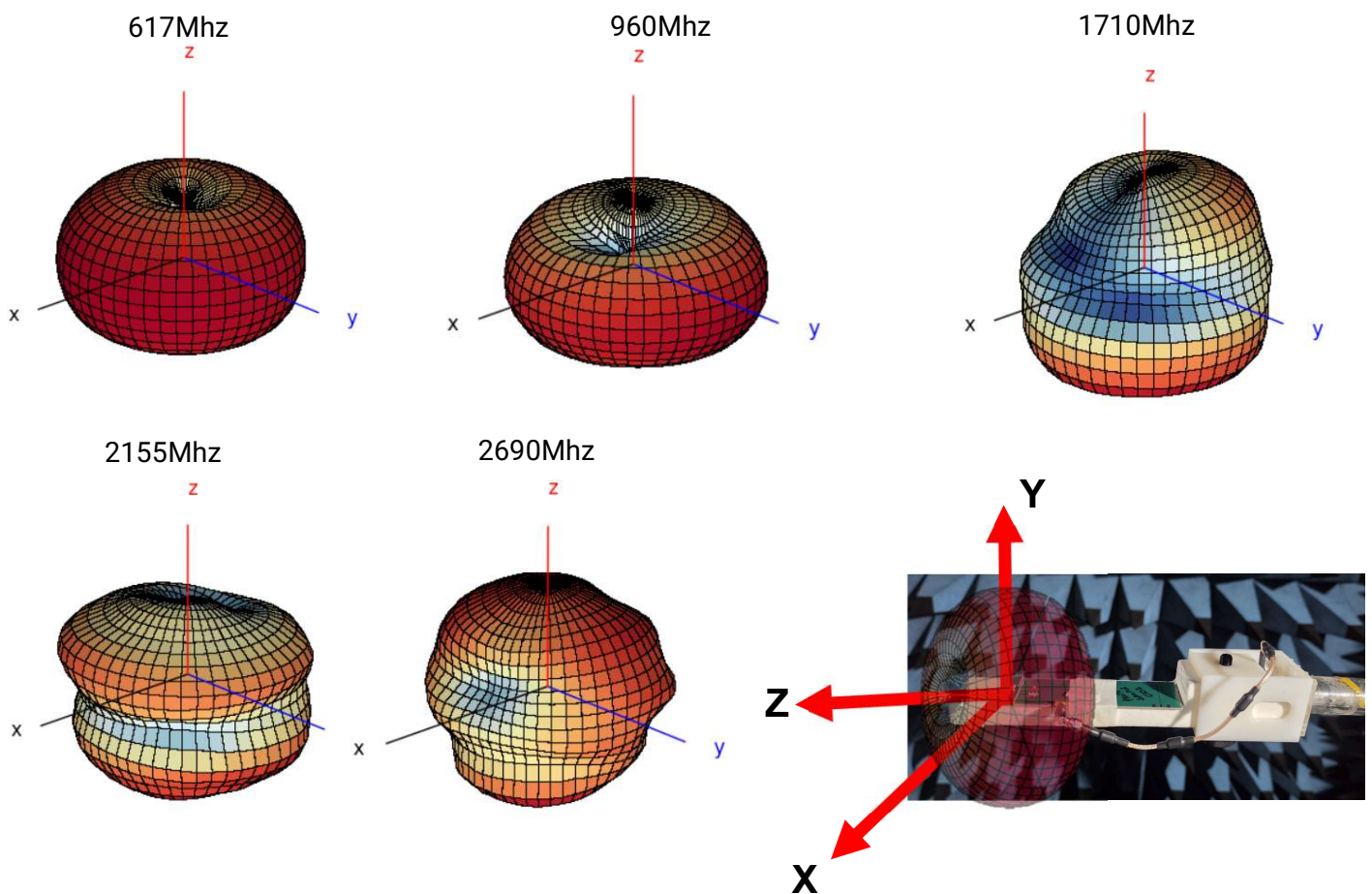

Dimension (unit: mm)



TOP VIEW

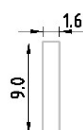

SIDE VIEW

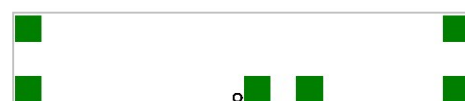

BOTTOM VIEW

TAEP162 FOOTPRINT

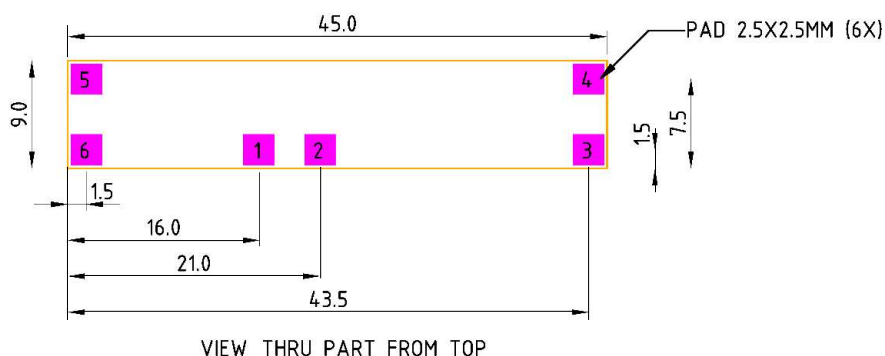

PIN	NAME
1	FEED
2	GND
3	NO CONNECT*
4	NO CONNECT*
5	NO CONNECT*
6	NO CONNECT*

*PADS 3 THRU 6 ARE FOR MOUNTING STRENGTH ONLY

SUGGESTED LAYOUT FOR ANTENNA MOUNTING

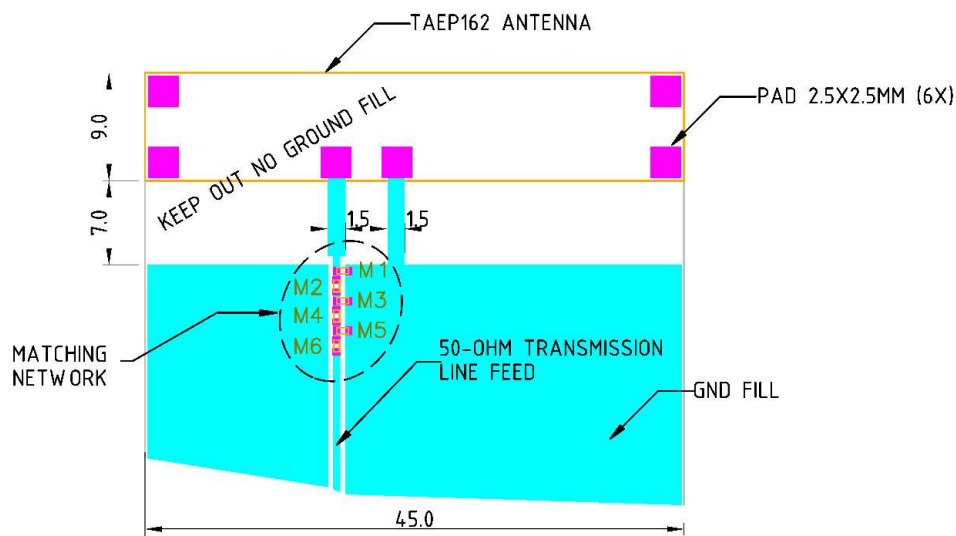

DESIGNATOR	TYPE	VALUE
M1	DO NOT USE	-
M2	RF CERAMIC CAPACITOR 0402 Hi-Q NP0/COG Tolerance +/- 0.1pF	2.4pF
M3	RF CERAMIC HF INDUCTOR 0402 Tolerance 5% SRF> 3GHz	12nH
M4	RF CERAMIC CAPACITOR 0402 Hi-Q NP0/COG Tolerance +/- 0.1pF	3.3pF
M5	DO NOT USE	-
M6	RF CERAMIC HF INDUCTOR 0402 Tolerance +/- 0.2 Nh SRF> 3GHz	3.3nH

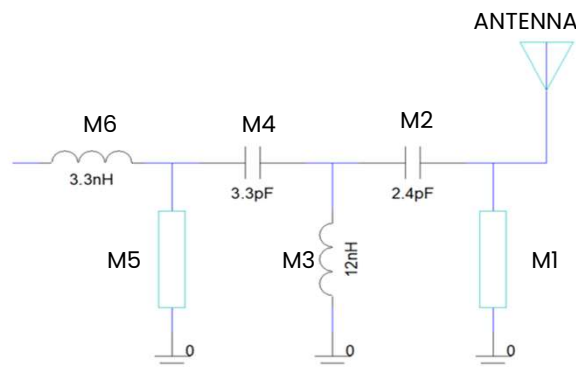

Cellular Antenna

TAEP162EVK

The TAEP162EVK provides a complete antenna assembly with SMA connector that may be used to evaluate the antenna. Assembly includes the reference PCB with SMA connector, RF matching components and TAEP162 antenna pre-assembled.

Dimension (unit: mm)

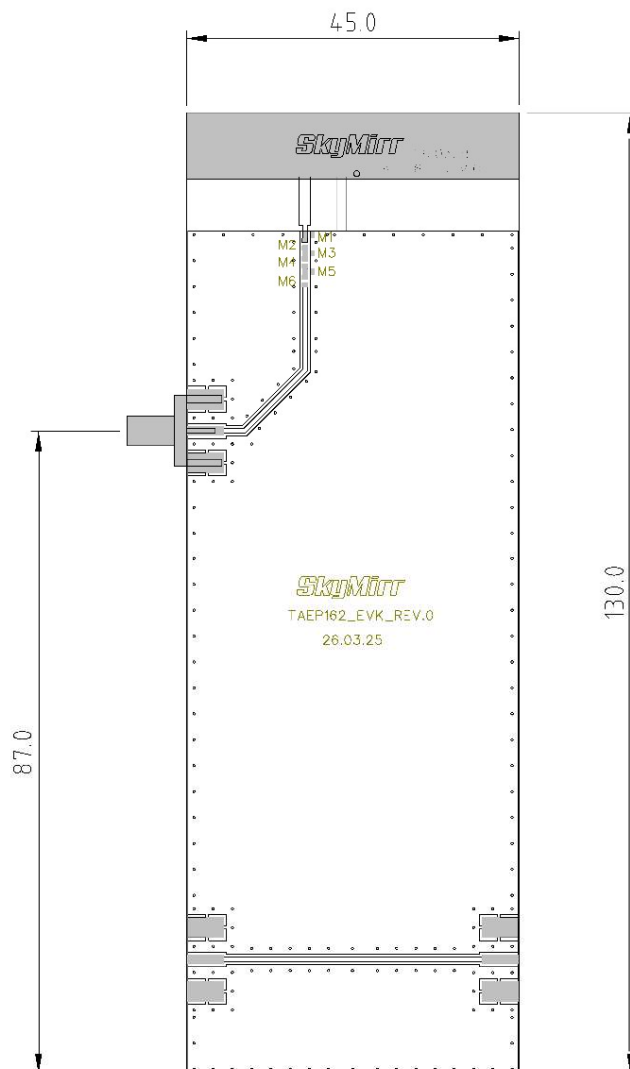

Efficiency And Peak Gain Table

Frequency [MHz]	617	652	663	698	703	716	729	746	756	777	787	803
Efficiency [dB]	-4.57	-3.82	-3.56	-2.69	-2.43	-2.84	-2.55	-3.18	-3.38	-2.27	-2.06	-2.09
Efficiency [%]	34.9	41.5	44.1	53.8	57.2	52.0	55.6	48.1	46.0	59.3	62.3	61.8
Peak Gain [dBi]	-2.28	-1.32	-1.17	-0.36	-0.10	-0.59	-0.38	-1.05	-1.21	-0.27	-0.04	0.08
Frequency [MHz]	824	849	869	894	915	925	960					
Efficiency [dB]	-1.58	-2.46	-1.69	-1.78	-1.86	-1.91	-1.83					
Efficiency [%]	69.4	56.8	67.7	66.4	65.2	64.5	65.7					
Peak Gain [dBi]	0.88	0.00	0.61	0.89	1.02	1.05	1.30					
Frequency [MHz]	1710	1755	1850	1910	1930	1990	2110	2155	2496	2593	2690	
Efficiency [dB]	-4.19	-2.78	-1.80	-1.75	-2.18	-1.09	-0.64	-0.48	-1.28	-1.39	-2.80	
Efficiency [%]	38.1	52.7	66.0	66.8	60.5	77.8	86.3	89.6	74.5	72.5	52.5	
Peak Gain [dBi]	0.53	2.15	2.65	2.04	1.64	2.89	3.66	3.60	2.83	3.22	1.08	

Measured VSWR

- 620 to 700 MHz: <4.2
- 700 to 960 MHz: <3.5
- 1710 to 2700MHz: <2.5

Measured Efficiency

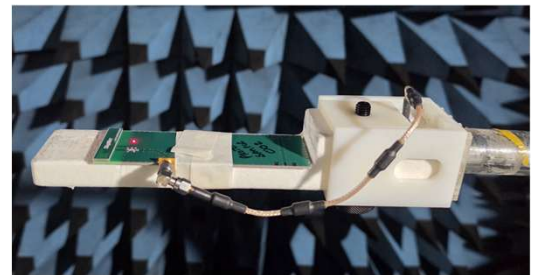
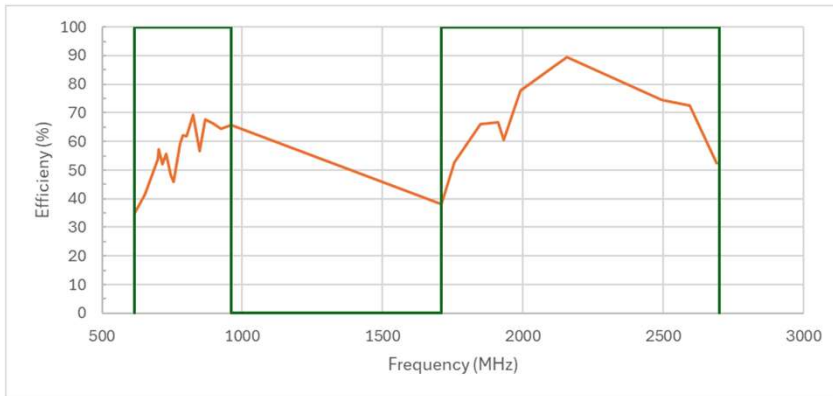

Cellular Antenna

INTRODUCTION

The TAMP172 is a wideband LTE 4G magnetic-mount antenna designed for stable, high-efficiency performance across 698–960 MHz and 1710–2700 MHz bands. With 3 dBi gain, 50Ω impedance, and a flexible 3-meter RG174 cable, it enables easy deployment and reliable signal reception in both fixed and mobile environments.

APPLICATIONS

The TAMP172 is ideal for routers, gateways, and IoT devices requiring quick, non-permanent installation. Its magnetic base allows for rapid placement on metal surfaces, making it well-suited for vehicles, fleet tracking, temporary deployments, industrial equipment, and remote monitoring systems where consistent LTE connectivity and installation flexibility are essential.



Key Specifications

- Frequency Ranges:
High Band: 1710-2700 MHz
Low Band: 698-960 MHz
- VSWR<2.0
- Impedance: 50Ω
- Gain: 3 dBi
- Polarization: Linear

Physical Characteristics

- Cable Length (mm): RG174 3m
- Connector: SMA Male
- Antenna Dimensions: $\phi 30 \times 220$ mm
- Installation: Magnet
- Material: PVC or Fiberglass

Operating Conditions

- Operating temperature range: -40°C to +85°C
- Vibration Resistance: Applied vibration of 10-55Hz with 1.5CM amplitude for 2 hours
- Humidity: 5-95%

Contact Details:

US: +1-3213931039

TW: +886-963383713

KR: +82-1047149824

IN: +91-9967297130

Email: sales@skymirr.com

Website: www.skymirr.com



Cellular Antenna

INTRODUCTION

The TAMP173 is a compact, screw-mount 4G LTE antenna designed for reliable wideband cellular performance across 698–960 MHz and 1710–2690 MHz. Featuring a low VSWR (<1.5), 50 Ω impedance, and durable IP65–IP67-rated housing, it delivers stable connectivity in demanding environments.

APPLICATIONS

Ideal for embedded and external cellular applications, the TAMP173 is well-suited for routers, gateways, IoT devices, and industrial equipment requiring dependable LTE connectivity. Its rugged, screw-mount design makes it particularly effective in outdoor deployments, vehicle systems, smart infrastructure, and remote monitoring solutions operating across harsh environmental conditions.

Key Specifications

- Frequency Ranges:
High Band: 1710-2690 MHz
Low Band: 698-960MHz
- VSWR<1.5
- Impedance: 50 Ω
- Polarization: Linear



Physical Characteristics

- Cable Length (mm): RG174 3000
- Connector: SMA Male
- Antenna Dimensions: $\phi 46.6 \times 14.5$ mm
- Installation: Screw
- Ingress Protection: IP64~IP67 (excluding cable outlet)

Operating Conditions

- Operating temperature range: -40°C to +85°C
- Vibration Resistance: Applied vibration of 10-55Hz(1.5CM amplitude) for 2 hours
- Humidity: 5-95%

Dimensions (unit: mm)

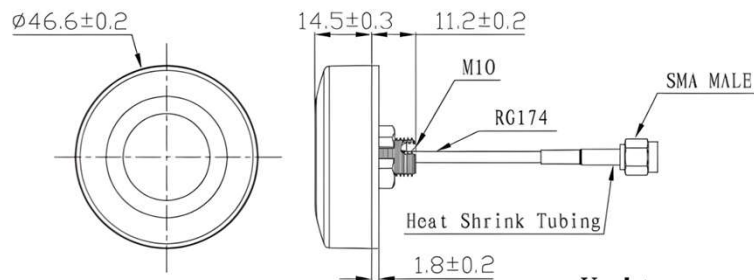

Unit: mm

Contact Details:

US: +1-3213931039

TW: +886-963383713

KR: +82-1047149824

IN: +91-9967297130

Email: sales@skymirr.com

Website: www.skymirr.com



INTRODUCTION

The TAEP121 is an omnidirectional Wi-Fi triple band antenna used to connect wireless communication devices such as laptop computers, printers, and cameras etc. to a Wi-Fi 6e router.

APPLICATION

Any wireless device that requires an embedded (internal) antenna covering Wi-Fi 6e frequency bands. Examples Uses – Routers, Gateways, CPEs, Automotive devices, IoT devices, etc.

Features and Benefits

- **Embedded Antenna Covering Wi-Fi 2.4/5/6 GHz Triple Bands**
- Antenna Size: 35.3 x 9mm (FPC)
- Connector: MHF1 (or MHF4) plug
- Coaxial Cable: $\Phi 1.13 \times 100\text{mm}$ (Length is customizable)
- Operating Frequency Bands:
 - 2400~2500Mhz
 - 5100~7125Mhz
- High Efficiency up to 85%
- Peak Gain: 1.5~3.8 dBi
- RoHS Compliance



Performance

Gain and Efficiency

Frequency [Mhz]	2.4Ghz Band			5Ghz Band						
	2401	2442	2478	5150	5220	5500	5750	5805	5825	5855
Efficiency [%]	78.0	85.0	81.5	55.6	56.9	71.0	80.2	70.5	71.2	78.3
Peak Gain [dBi]	1.51	1.80	1.60	1.69	1.39	3.38	3.77	3.29	3.27	3.66
Impedance	50 Ω									
Polarization	Vertical									
Direcitivity	Omni Directional									

VSWR

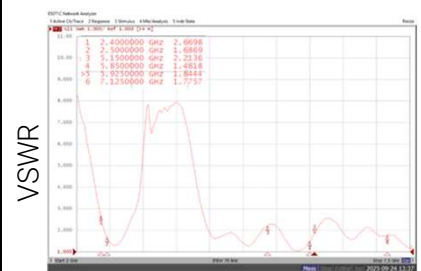

VSWR

Frequency (MHz)

Radiation Pattern

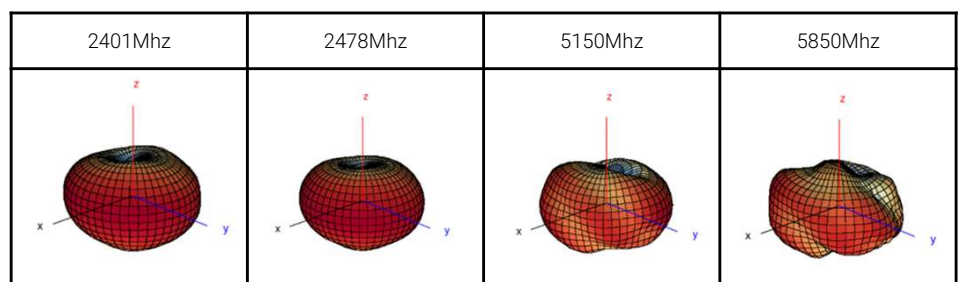

Contact Details:

US: +1-3213931039

TW: +886-963383713

KR: +82-1047149824

IN: +91-9967297130

Email: sales@skymirr.com

Website: www.skymirr.com

Dimension (unit: mm)

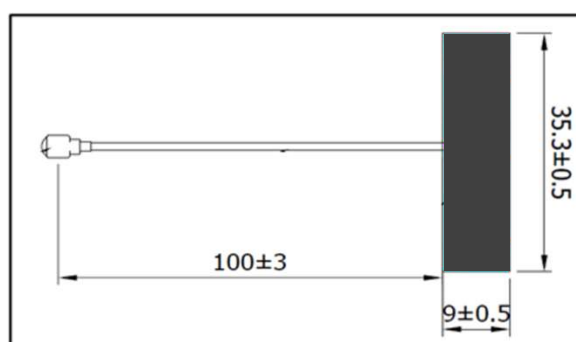

INTRODUCTION

The TAMP118 is an omnidirectional Wi-Fi external antenna used for connecting wireless communication equipment such as a Wi-Fi 6e, Wi-Fi7 router to client devices.

APPLICATION

Any wireless device that requires an antenna covering Wi-Fi frequency bands. Examples Uses – Routers, Gateways, CPEs, Automotive devices, IoT devices, etc.

Features and Benefits

- External Antenna with Hinge Covering WiFi 2.4/5/6 GHz Triple Bands
- Antenna Size: 156.4 X Φ 13mm
- Connector: SMA male
- Color: Black / White
- Operating Frequency Bands:
 - 2400~2500MHz
 - 5100~5900MHz
 - 5925~7125MHz
- High Efficiency up to 90%
- Peak Gain: 1.9~4.1 dBi



Performance

Gain and Efficiency

	Frequency [MHz]	2.4GHz Band			5GHz Band				6GHz band			
		2401	2442	2478	5150	5500	5805	5855	5955	6419	6651	7115
Unfolded	Efficiency [%]	68.2	72.7	74.3	63.0	66.8	73.9	77.2	75.3	63.9	64.2	50.5
	Peak Gain [dBi]	2.70	3.05	3.26	1.88	3.15	2.35	2.70	2.52	2.99	3.40	2.15
Folded	Efficiency [%]	79.8	88.2	85.0	67.2	81.5	85.4	89.5	86.1	71.8	71.2	57.5
	Peak Gain [dBi]	2.93	3.26	3.11	2.31	3.20	3.91	3.91	3.10	3.57	4.12	3.03
Impedance	50 Ω											
Polarization	Vertical											
Directivity	Omni Directional											

VSWR

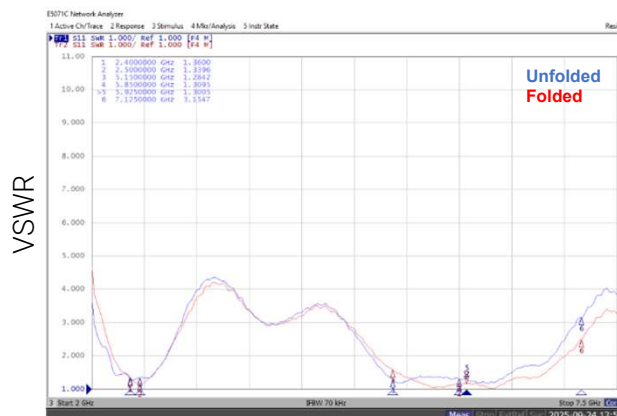

Frequency (MHz)

Contact Details:

US: +1-3213931039
TW: +886-963383713
KR: +82-1047149824
IN: +91-9967297130
Email: sales@skymirr.com
Website: www.skymirr.com

Radiation Patterns

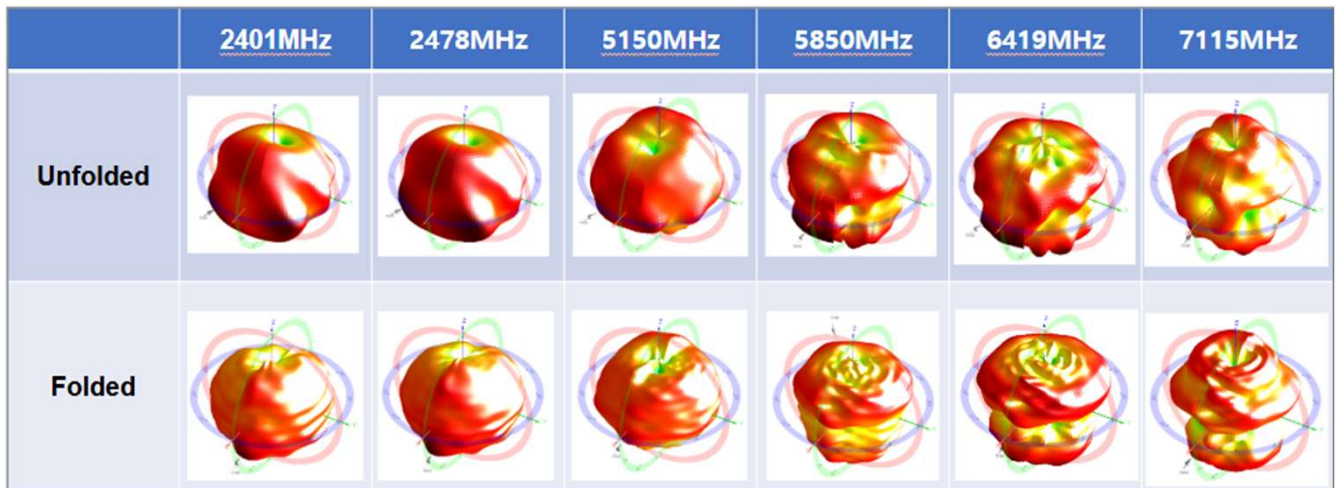

Dimension (unit: mm)

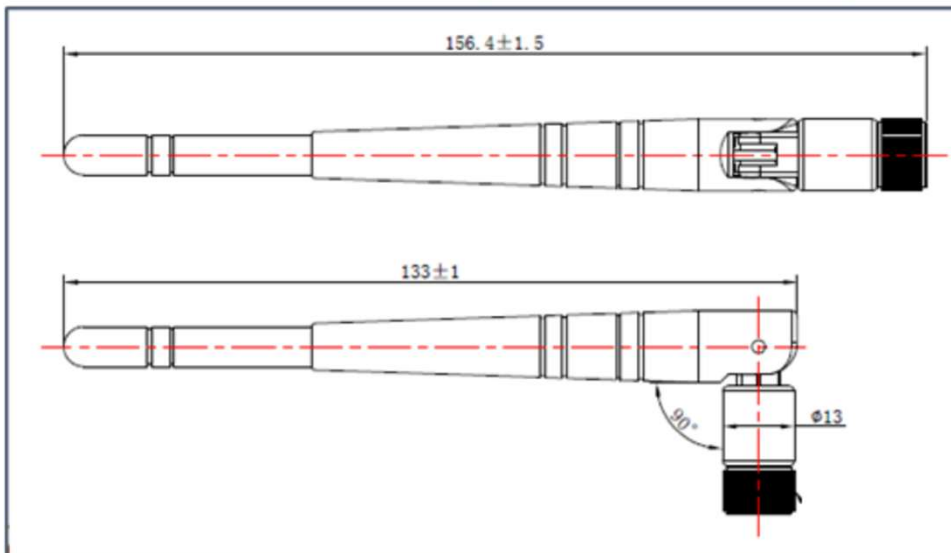

INTRODUCTION

TAEP169 is a compact, high-efficiency **dual-band SMD ceramic antenna** engineered for modern wireless connectivity. Utilizing a **multi-layer internal structure**, it supports operation across both 2.4 GHz and 5 GHz frequency bands, enabling reliable performance for Wi-Fi, Bluetooth, and other short-range wireless protocols.

APPLICATIONS

This antenna is intended for short-range wireless communication systems operating in the 2.4 GHz and 5 GHz bands. Typical applications include:
 Wi-Fi (2.4 GHz / 5 GHz) devices and routers
 Bluetooth-enabled products and wearables
 Smart home and IoT devices
 Wireless modules in consumer electronics (tablets, laptops, cameras)

Contact Details:

US: +1-3213931039

TW: +886-963383713

KR: +82-1047149824

IN: +91-9967297130

Email: sales@skymirr.com

Website: www.skymirr.com

Key Specifications

- Antenna Size: 3.2±0.2 x 1.6±0.2 x 1.2±0.1mm
- Frequency Range: 2400–2500 MHz and 5150–5850 MHz
- Peak Gain 2.23 dBi at 2450 MHz and 4.05 dBi at 5500MHz
- Bandwidth: 100MHz for the lower band and 800MHz for the higher band.
- Polarization: Linear
- Azimuth Beam Width: Omnidirectional
- Return Loss -7dB (max)
- Impedance: 50 Ω



Operating Conditions

- Operating temperature range is -40°C to +85°C
- Storage temperature range is -40°C to +85°C
- Vibration Resistance: Applied vibration of 10-55Hz (1.5mm amplitude) for 2 hours each in X,Y, and Z Directions
- Storage Environment: Less than 30°C with humidity below 85%
- Moisture sensitivity level 1

Soldering and Handling

- **Product can withstand 255°C ± 10°C for 5 seconds or an electric iron at 300°C - 10°C for 3 seconds.** This device is compatible with lead-free soldering processes, specifically Sn (tin) soldering at 255°C
- **Usage Requirement:** The product should be used within six months of receipt.

Dimensions (unit: mm)

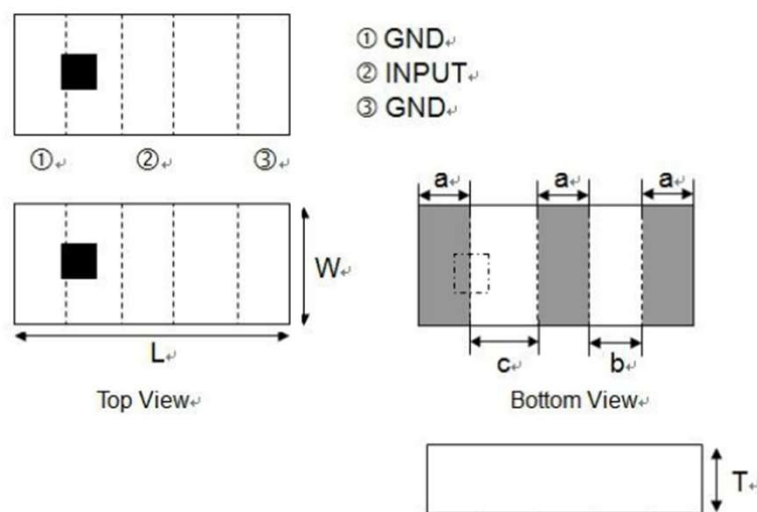

Symbol	L	W	T	a	b	c
Dimensions	3.2±0.2	1.6±0.2	1.2±0.1	0.5±0.1	0.7±0.1	1.0±0.1



EVB (Evaluation Board)

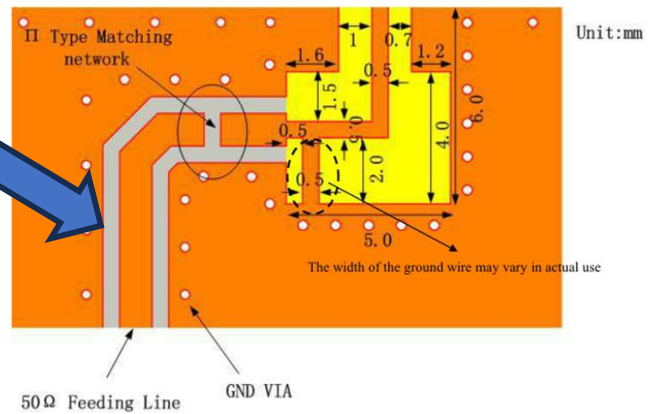
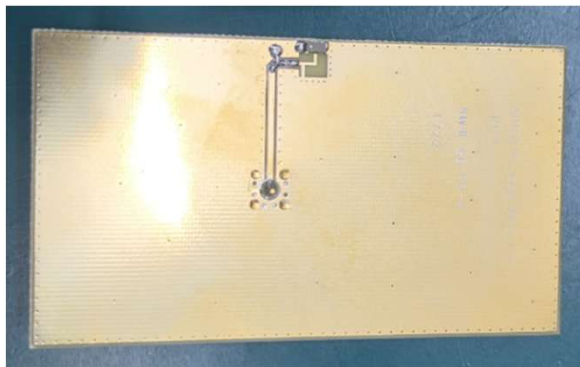
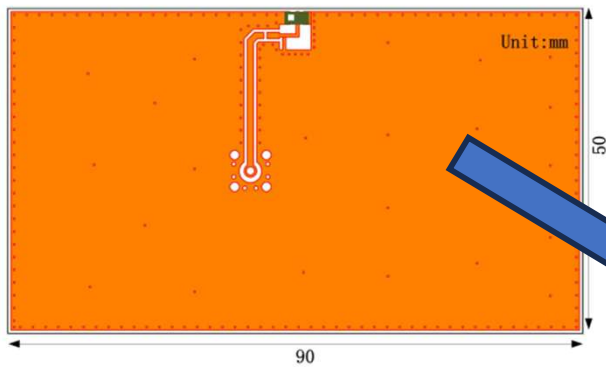

Performance

VSWR

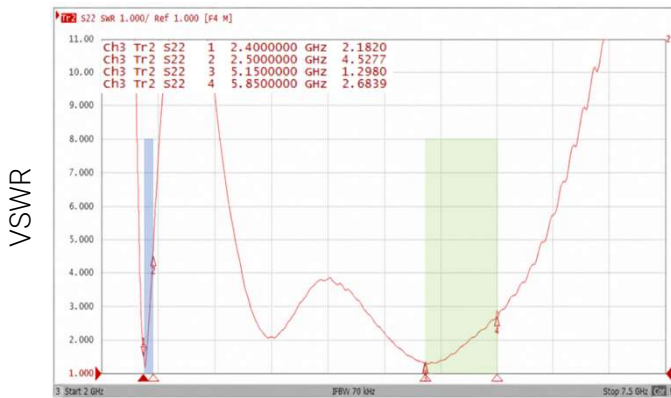

Frequency (MHz)

Efficiency

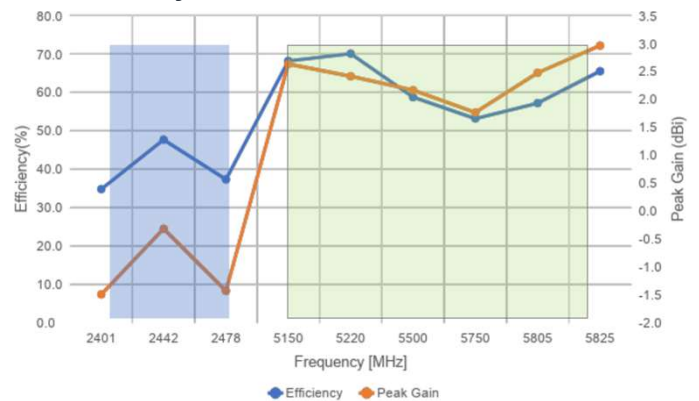

Frequency [MHz]	2.4GHz			5GHz						
	2401	2442	2478	5150	5220	5500	5750	5805	5825	5855
Efficiency (%)	34.8	47.7	37.4	68.2	70.1	58.7	53.2	57.2	65.5	64.5
Peak Gain (dBi)	-1.49	-0.31	-1.43	2.63	2.41	2.16	1.77	2.48	2.96	2.56

Radiation Patterns

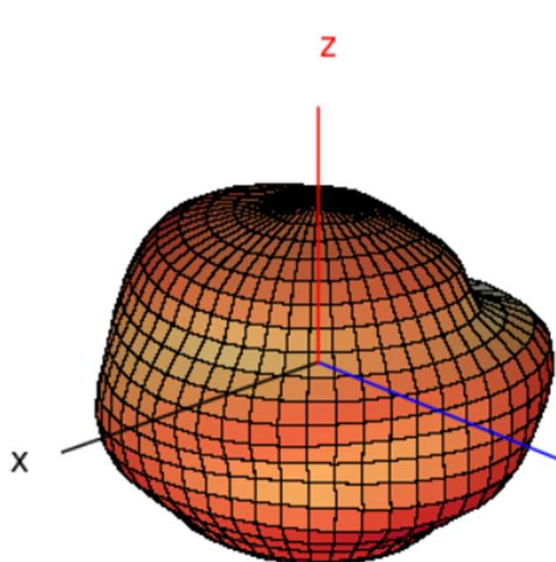

2401MHz

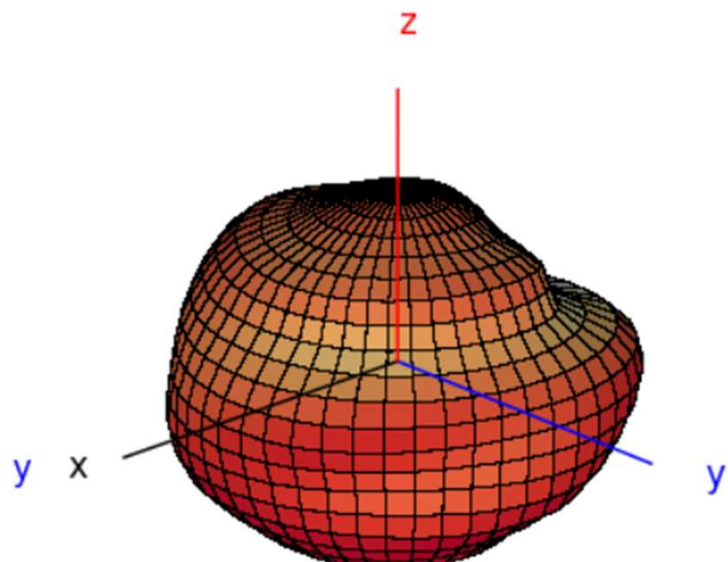

2478MHz

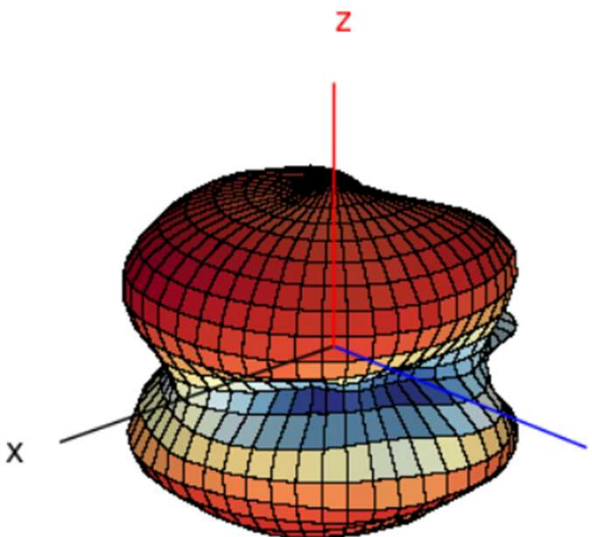

5150MHz

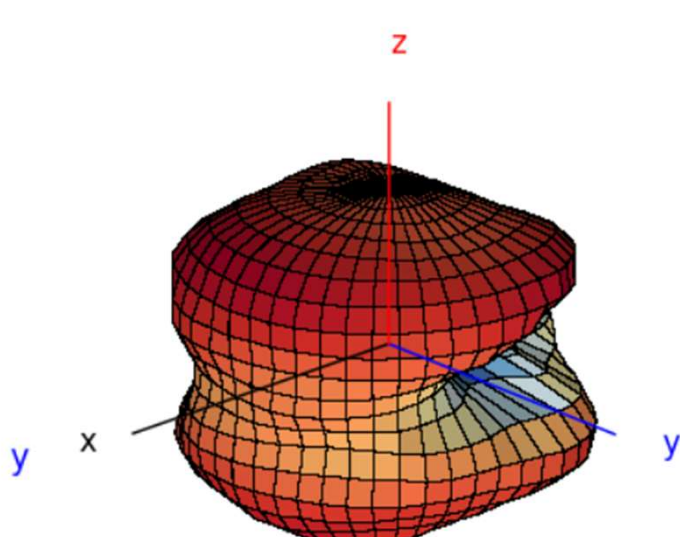

5855MHz

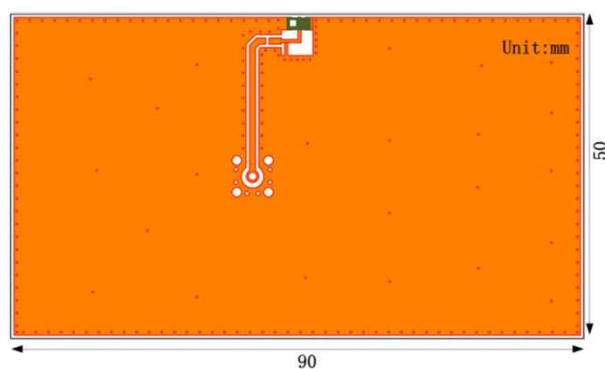
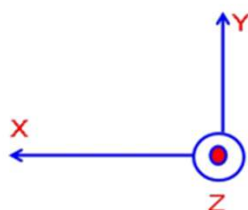

Characteristic Curve

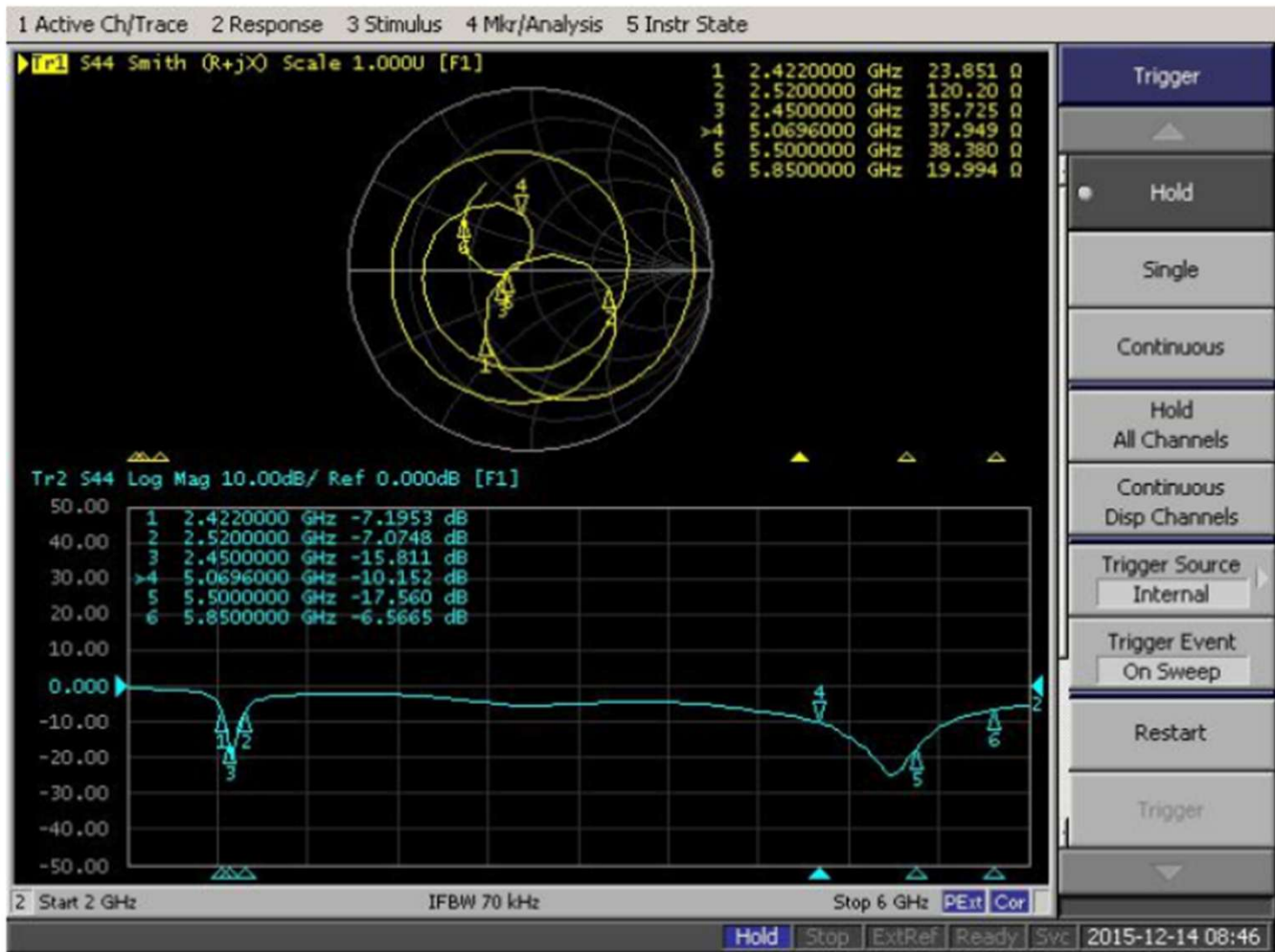

INTRODUCTION

The TAMP159 is an omnidirectional Wi-Fi external antenna used for connecting wireless communication equipment such as a Wi-Fi 6e, Wi-Fi7 router to client devices.

APPLICATION

Any wireless device that requires an antenna covering Wi-Fi frequency bands. Examples Uses – Routers, Gateways, CPEs, Automotive devices, IoT devices, etc.

Features and Benefits

- External Antenna with Hinge Covering WiFi 2.4/5/6 GHz Triple Bands
- Antenna Size: 156.1 X Φ 13mm
- Connector: SMA male (RP-SMA Available upon request)
- Color: Black / White
- Operating Frequency Bands:
 - 2400~2500MHz
 - 5100~5900MHz
 - 5925~7125MHz
- High Efficiency up to 95%
- Peak Gain: 2.2~4.6 dBi
- Operating Temperature Range: -40°C to +85°C



Performance

Gain and Efficiency

	Frequency [Mhz]	2.4GHz Band			5GHz Band				6GHz band			
		2401	2442	2478	5150	5500	5805	5855	5955	6419	6651	7115
Unfolded	Efficiency [%]	79.0	86.4	86.6	72.4	68.4	85.4	73.4	71.6	66.9	64.5	63.7
	Peak Gain [dBi]	3.31	3.50	3.16	3.41	2.52	3.73	2.99	3.04	2.52	2.95	3.10
Folded	Efficiency [%]	86.3	94.6	93.9	78.5	81.1	93.6	88.7	82.7	74.3	72.8	73.7
	Peak Gain [dBi]	2.76	2.62	2.27	4.12	4.04	4.63	4.55	4.05	3.15	3.61	3.98
Impedance		50 Ω										
Polarization		Vertical										
Directivity		Omni Directional										

VSWR

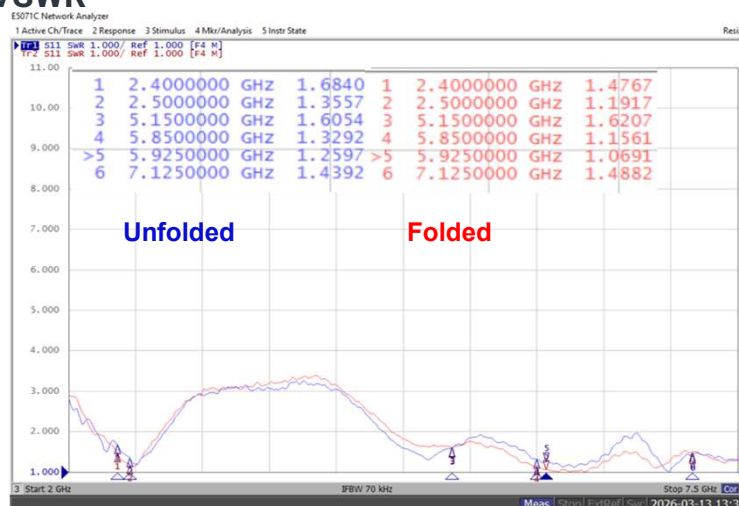

Contact Details:

US: +1-3213931039

TW: +886-963383713

KR: +82-1047149824

IN: +91-9967297130

Email: sales@skymirr.com

Website: www.skymirr.com



Radiation Pattern

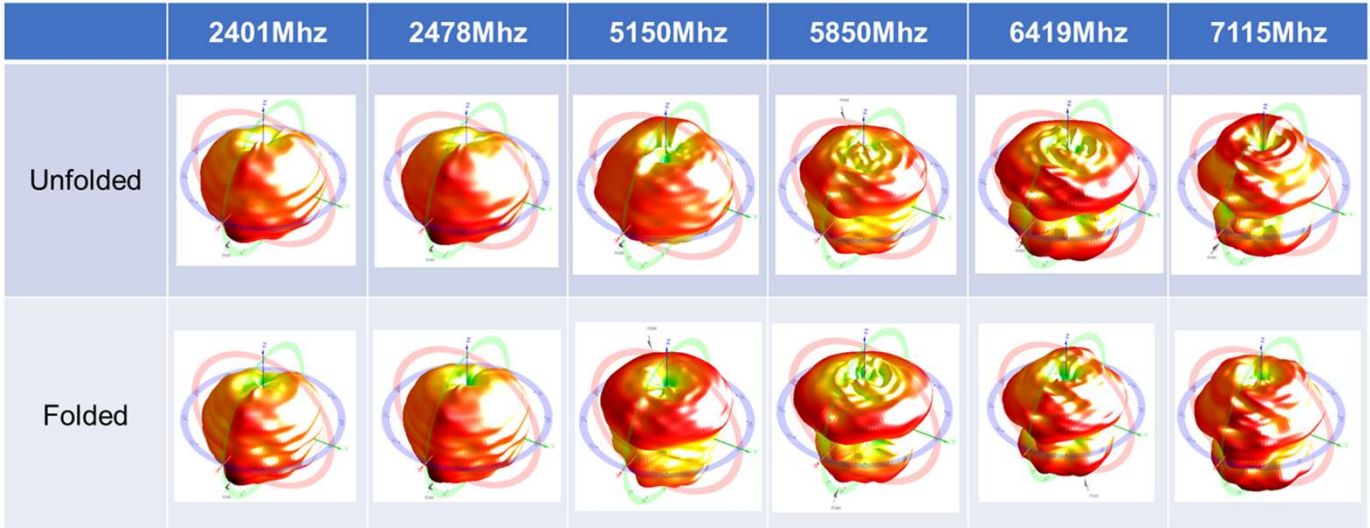

Dimension (unit: mm)

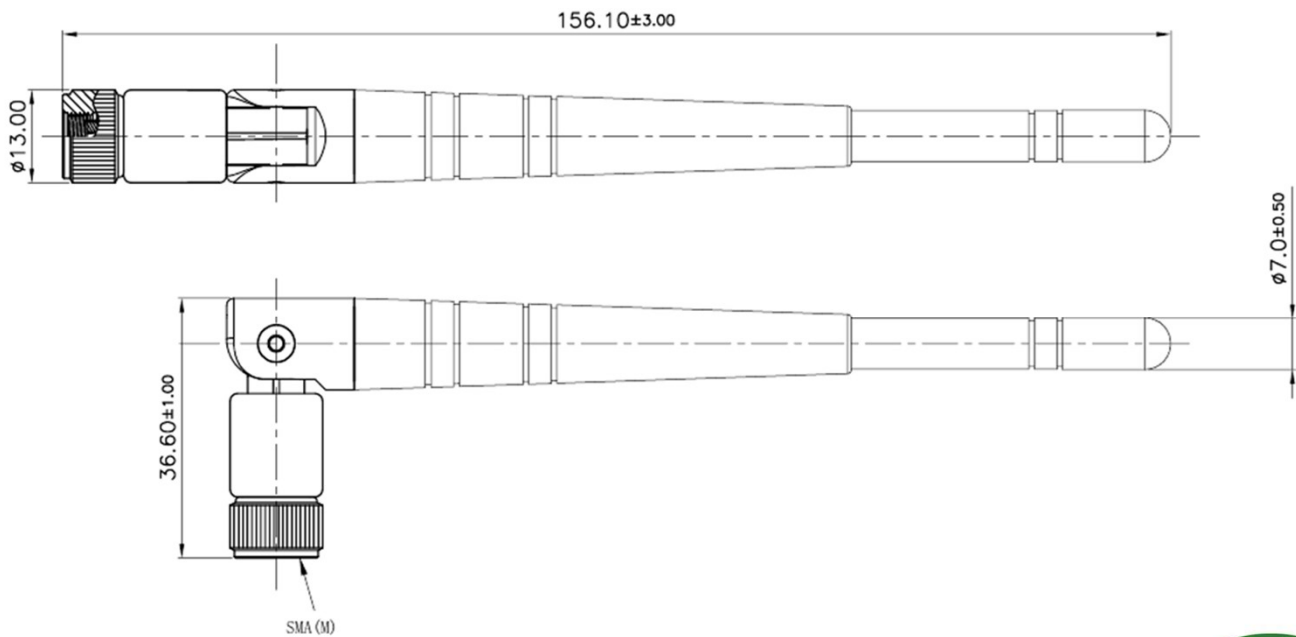

INTRODUCTION

The SkyMirr TAMP156 WiFi Directional Antenna delivers high-gain, high-efficiency performance across the 2.4 GHz, 5 GHz, and 6 GHz WiFi bands. With efficiency up to 77% and peak gain ranging from 6.6 to 10.0 dBi, it provides focused, reliable signal delivery where standard antennas fall short. Its directional beam improves throughput, reduces interference, and extends usable range—ideal for environments that demand stable and targeted RF performance.

APPLICATIONS

- **Indoor coverage enhancement** for offices, homes, and commercial buildings
- **Warehouse and industrial connectivity**, delivering focused RF along aisles or long corridors
- **Point-to-point WiFi links** requiring directional precision
- **WiFi 6 / WiFi 7 access points** needing stronger, targeted performance
- **CPEs, repeaters, and IoT gateways** that benefit from high-gain, triple-band support

Contact Details:

US: +1-3213931039

TW: +886-963383713

KR: +82-1047149824

IN: +91-9967297130

Email: sales@skymirr.com

Website: www.skymirr.com

Features and Benefits

- External directional Antenna with Hinge Covering
- WiFi 2.4/5.2/6 GHz Triple Bands
- Operating Frequency Bands
 - 2400~2500MHz
 - 5100~5900MHz
 - 5925~7125MHz
- High Efficiency up to 77%
- Peak Gain: **6.6-10.0 dBi**
- Connector: SMA (Male)



Performance

Electrical			
Frequency Range	2400-2500 MHz	5150-5850 MHz	5945-7125 MHz
Gain (Peak)	7.0 dBi	10.0 dBi	9.6 dBi
VSWR	≤2.0	≤2.5	≤2.5
Efficiency (Peak)	90%	93%	88%
Input Imped.	50Ω		
Antenna Type	Directional		
Power Rating	10 W		
Mechanical (Antenna)			
Antenna	Radome Color	Black	
	Dimensions (w x h x d)	75.52 x 133.58 x 25.26 mm	
Connector	SMA-Male		
Weight	60g		

VSWR

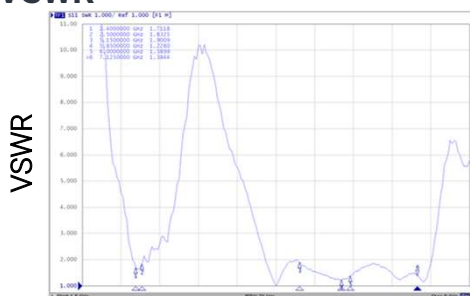

Frequency (MHz)

Peak / Gain Efficiency

Frequency [MHz]	2401	2442	2478	5150	5220	5500	5750	5805	5825	5855	5955	6187	6419	6651	6883	7115
Efficiency [%]	89.6	87.3	90.3	72.6	76.8	90.7	94.2	80.9	80.6	93.4	88.7	72.6	72.0	73.6	73.8	69.8
Peak Gain [dBi]	7.1	6.7	6.7	8.8	9.0	9.8	9.98	9.1	9.2	10.0	9.7	8.6	8.2	8.1	8.2	8.3

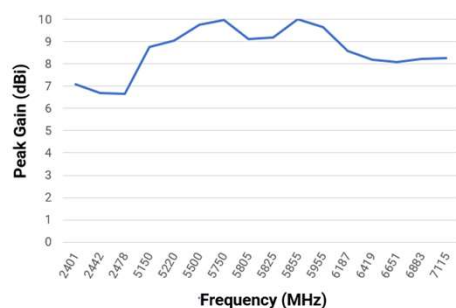
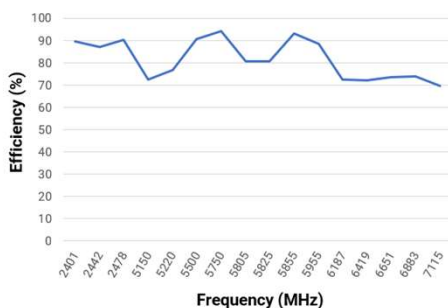

TAMP156

WiFi 6e/7 High Gain Directional Antenna

WiFi 6/7
Antennas
And
Modules

Radiation Pattern

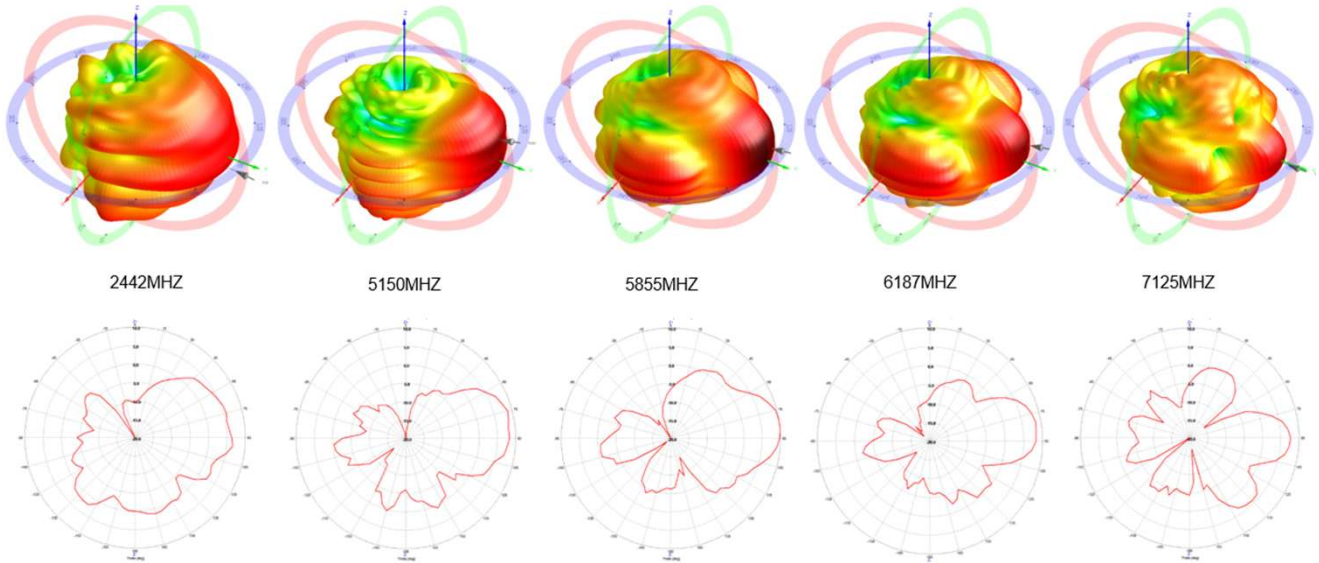

Antenna Radiation Direction

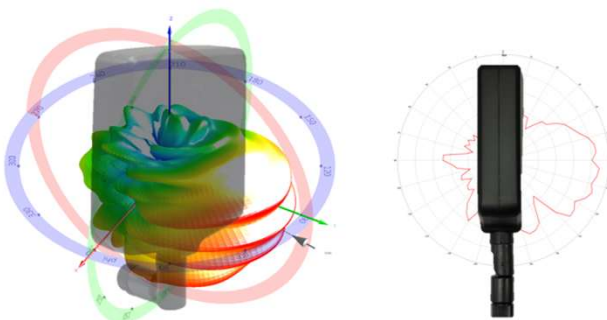

Dimension (unit: mm)

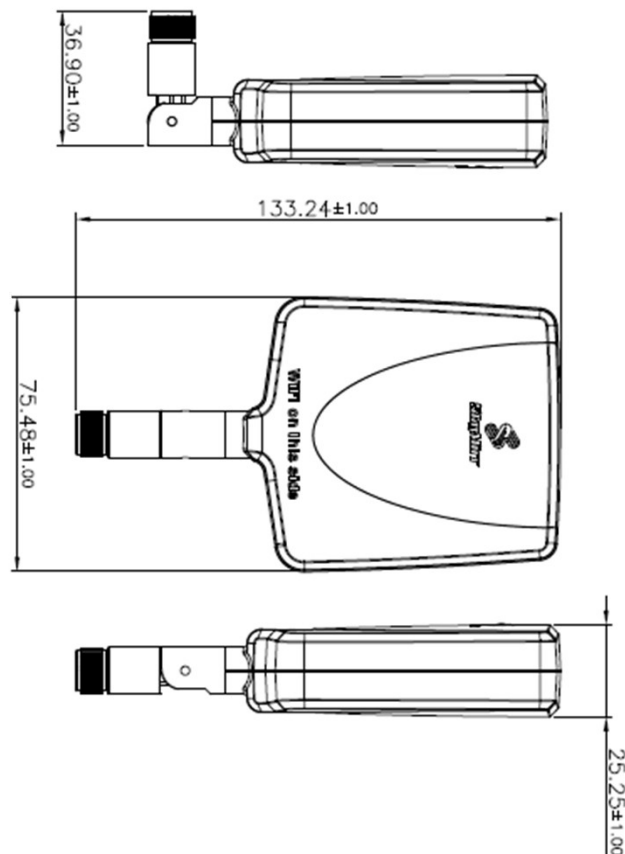

TAEP134

4G LTE/ 5G Sub6 and GNSS L1
Ultra-Broadband FPCB Antenna

Features and Benefits

- Ultra-Wideband FPCB Antenna Covering Entire 4G LTE/ 5G Sub 6 and GNSS L1 bands
- Antenna Size: 136.4 mm x 26.4 mm x 0.5 mm (not including Cable and Connector)
- Connector: WFL (Male) connector with a 150mm coaxial cable
- Operating Frequency Bands
 - 617~960MHz
 - 1432~2690MHz
 - 3300~5925MHz
 - GNSS L1: 1575.42 MHz
- High efficiency up to 93%
- Peak Gain: -2.7~4.5dBi
- RoHS Compliance

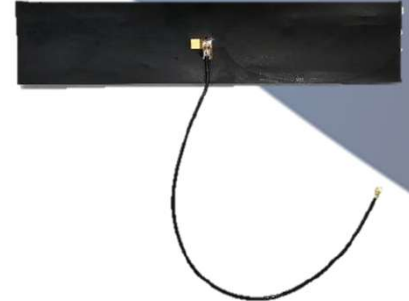

INTRODUCTION

The TAEP134 antenna is an omni-directional, FPCB antenna for any 4G/5G devices. TAEP134 can cover entire 4G/5G bands from 617MHz to 5GHz plus GNSS L1 band. This product particularly works fine with the 4G/5G module including Quectel RM520N (Ant 3 port).

APPLICATION

Any wireless device that requires a high efficiency antenna covering entire 4G LTE/5G Sub6 and GNSS L1 frequency bands.

Example Uses – Routers, Gateways, CPEs, Automotive devices, IoT devices, etc.

Performance

Gain and Efficiency

Frequency [Mhz]	Low Band				L1	Mid/High Band					Ultra High Band				LAA	
	617	746	824	960	1575	1432	1710	2170	2496	2690	3300	3800	4200	5000	5150	5925
Efficiency [%]	31.0	76.8	93.0	87.1	67.7	39.0	54.9	72.6	78.4	73.1	71.8	67.3	66.4	43.8	42.1	59.3
Peak Gain [dBi]	-2.70	1.70	2.68	3.39	3.28	0.78	1.31	3.05	4.49	4.36	4.16	3.45	2.85	1.56	1.65	3.04
Impedance	50Ω															
Polarization	Vertical															
Directivity	Omni Directional															

Radiation Pattern

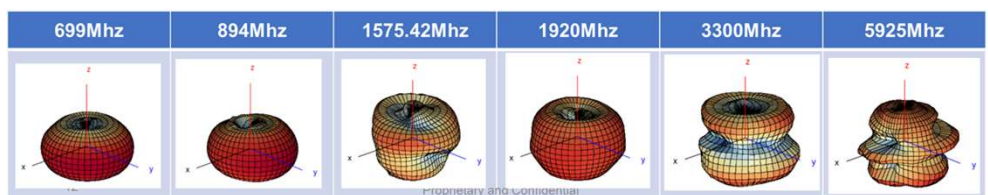

Dimension (unit: mm) VSWR

Contact Details:

US: +1-3213931039

TW: +886-963383713

KR: +82-1047149824

IN: +91-9967297130

Email: sales@skymirr.com

Website: www.skymirr.com

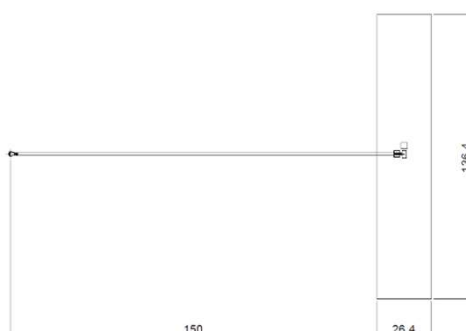

INTRODUCTION

The TAEP132 antenna is an omni-directional, FPCB antenna for any 4G/5G devices. TAEP132 can cover entire frequency bands from 1452MHz to 5GHz, and 1176MHz for GNSS L5. This product particularly works fine with the 4G/5G module including Quectel RM520N (Ant 1 port).

APPLICATION

Any wireless device that requires a high efficiency antenna covering entire 4G LTE/5G Sub6 and GNSS L5 frequency bands.

Example Uses – Routers, Gateways, CPEs, Automotive devices, IoT devices, etc.

Features and Benefits

- Ultra-Wideband FPCB Antenna Covering 4G LTE/5G Sub 6 Mid & High Bands plus GNSS L5 band
- Antenna Size: 83.9 mm x 26.4 mm x 0.5 mm (not including Cable and Connector)
- Connector: WFL (Male) connector with a 150mm coaxial cable
- Operating Frequency Bands
 - 1432~2690MHz
 - 3300~5925MHz
 - GNSS L5: 1176.45 MHz
- High efficiency up to 82%
- Peak Gain: -1.1~2.5dBi
- RoHS Compliance



Performance

Gain and Efficiency

Frequency [Mhz]	L5		Mid/High Band					Ultra High Band					LAA	
	1176	1432	1710	1920	2170	2496	2690	3300	3800	4200	4400	5000	5150	5925
Efficiency [%]	77.6	42.1	68.5	72.1	60.9	55.9	60.4	75.0	69.1	58.7	51.0	43.7	41.1	49.3
Peak Gain [dBi]	2.71	-1.12	2.18	1.88	0.58	0.78	1.37	2.07	2.53	2.27	2.19	1.22	1.01	0.98
Impedance	50Ω													
Polarization	Vertical													
Directivity	Omni Directional													

Radiation Pattern

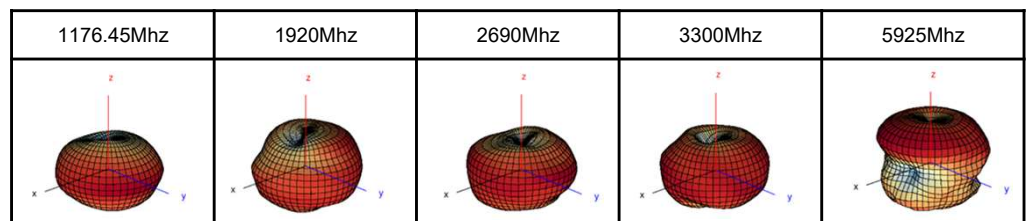

Dimension (unit: mm)

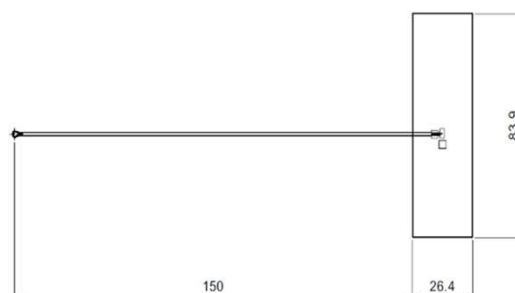

VSWR



Contact Details:

US: +1-3213931039

TW: +886-963383713

KR: +82-1047149824

IN: +91-9967297130

Email: sales@skymirr.com

Website: www.skymirr.com

INTRODUCTION

The TAEP131 antenna is an omni-directional, FPCB antenna for any 4G/5G devices. TAEP131 can cover entire frequency bands from 600MHz to 6GHz. This product particularly works fine with the 4G/5G module including Quectel RM520N (Ant 0 port).

APPLICATION

Any wireless device that requires a high efficiency antenna covering entire 4G LTE and 5G Sub6 frequency bands.

Example Uses – Routers, Gateways, CPEs, Automotive devices, IoT devices, etc.

Features and Benefits

- Ultra-Wideband FPCB Antenna Covering ALL 4G LTE and 5G Sub 6 Bands
- Antenna Size: 136.4 mm x 26.4 mm x 0.5 mm (not including Cable and Connector)
- Connector: WFL (Male) with a 150mm coaxial cable
- Operating Frequency Bands
 - 617~960MHz
 - 1432~2690MHz
 - 3300~5000MHz
- High efficiency up to 92%
- Peak Gain: -3.0~4.8dBi
- RoHS Compliance

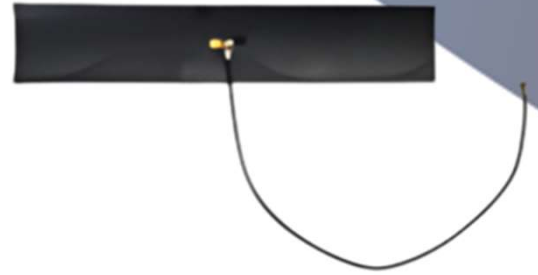

Performance

Gain and Efficiency

	Low Band				Mid/High Band						Ultra High Band				
	617	746	824	960	1432	1710	1920	2170	2360	2690	3300	3800	4200	4400	5000
Efficiency [%]	30.6	80.5	92.0	83.0	34.9	50.7	54.4	71.6	60.2	77.2	67.5	58.7	60.3	53.8	41.7
Peak Gain [dBi]	-3.03	1.82	3.01	3.57	-0.56	1.30	2.27	3.04	2.53	4.81	4.66	4.09	3.69	3.79	3.00
Impedance	50Ω														
Polarization	Vertical														
Directivity	Omni Directional														

Radiation Pattern

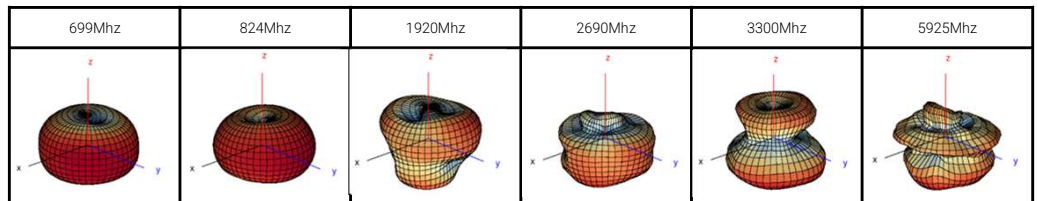

Contact Details:

US: +1-3213931039

TW: +886-963383713

KR: +82-1047149824

IN: +91-9967297130

Email: sales@skymirr.com

Website: www.skymirr.com

Dimension (unit: mm)

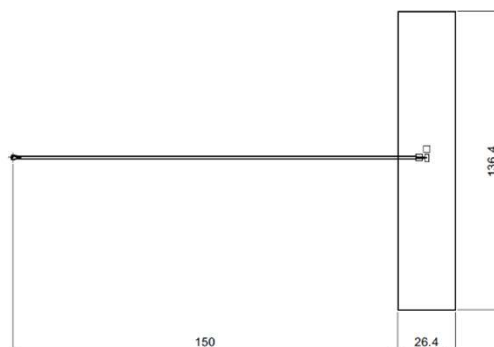

VSWR



Frequency (MHz)

INTRODUCTION

The TAEP133 antenna is an omni-directional, FPCB antenna for any 4G/5G devices. TAEP133 can cover entire frequency bands from 1452MHz to 5GHz. This product particularly works fine with the 4G/5G module including Quectel RM520N (Ant 2 port).

APPLICATION

Any wireless device that requires a high efficiency antenna covering entire 4G LTE/5G Sub6 frequency bands.

Example Uses – Routers, Gateways, CPEs, Automotive devices, IoT devices, etc.

Contact Details:

US: +1-3213931039

TW: +886-963383713

KR: +82-1047149824

IN: +91-9967297130

Email: sales@skymirr.com

Website: www.skymirr.com

Features and Benefits

- Ultra-Wideband FPCB Antenna Covering 4G LTE/ 5G Sub 6 Mid & High Bands
- Antenna Size: 62.4 mm x 26.4 mm x 0.5 mm (not including Cable and Connector)
- Connector: WFL (Male) connector with a 150mm coaxial cable
- Operating Frequency Bands
 - 1452~2690MHz
 - 3300~5000MHz
- High efficiency up to 80%
- Peak Gain: -1.2~3.5dBi
- RoHS Compliance



Performance

Gain and Efficiency

Frequency [MHz]	Mid/High Band						Ultra High Band				
	1432	1710	1920	2170	2305	2690	3300	3800	4200	4400	5000
Efficiency [%]	42.6	67.9	78.1	72.5	59.3	67.8	71.9	58.1	46.9	43.2	40.4
Peak Gain [dBi]	-0.84	1.66	2.19	2.01	1.16	2.10	3.43	2.77	1.22	1.07	-1.23
Impedance	50Ω										
Polarization	Vertical										
Directivity	Omni Directional										

Radiation Pattern

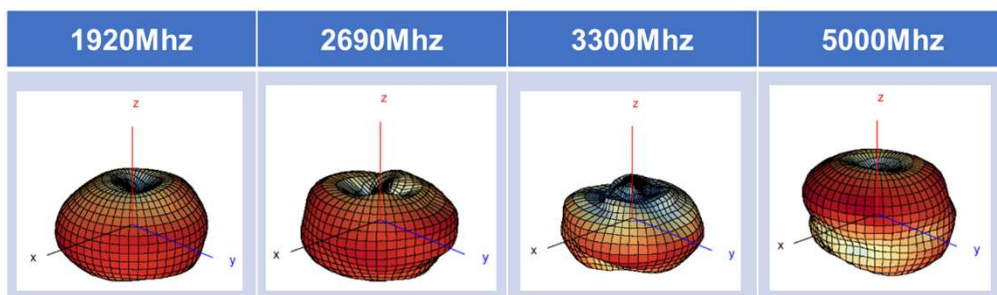

Dimension (unit: mm)

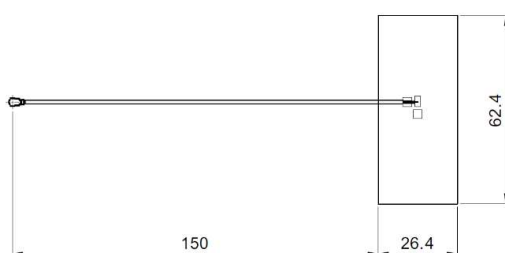

VSWR



Frequency (MHz)

INTRODUCTION

The TAEP135 antenna is a high-performance FPCB antenna optimized for WiFi6e/7 applications. TAEP135 can cover WiFi 6e/7 bands at 2400/ 5200/ 7100MHz.

APPLICATION

Any wireless device that requires a high efficiency antenna covering entire WiFi 6e/7 frequency bands.

Example Uses – Routers, Gateways, CPEs, Automotive devices, IoT devices, etc.

Features and Benefits

- **Ultra-Wideband FPCB Antenna Covering Entire WiFi 6e/7 bands**
- Antenna Size: 35.4 mm x 13.4 mm x 0.5 mm (not including Cable and Connector)
- Connector: UFL (Male) connector with a 150mm coaxial cable
- Operating Frequency Bands
 - 2400~2500MHz
 - 5150~7125MHz
- High efficiency up to 85%
- Peak Gain: 1.0~3.5dBi
- RoHS Compliance



Performance

Gain and Efficiency

Frequency [Mhz]	2.4Ghz Band			5Ghz Band						
	2401	2442	2478	5150	5220	5500	5750	5805	5825	5855
Efficiency [%]	79.3	84.8	81.1	63.0	56.9	72.8	69.5	68.6	75.9	85.5
Peak Gain [dBi]	2.34	2.86	2.71	1.50	1.09	2.39	2.41	2.29	2.90	3.50
Impedance	50Ω									
Polarization	Vertical									
Directivity	Omni Directional									

VSWR

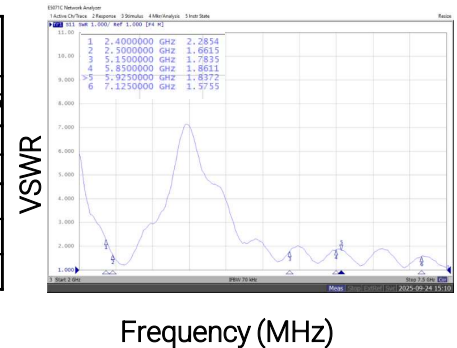

Radiation Pattern

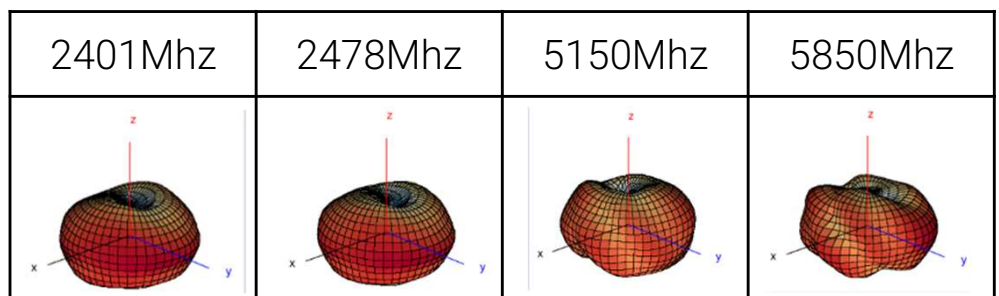

Contact Details:

US: +1-3213931039

TW: +886-963383713

KR: +82-1047149824

IN: +91-9967297130

Email: sales@skymirr.com

Website: www.skymirr.com

Dimension (unit: mm)

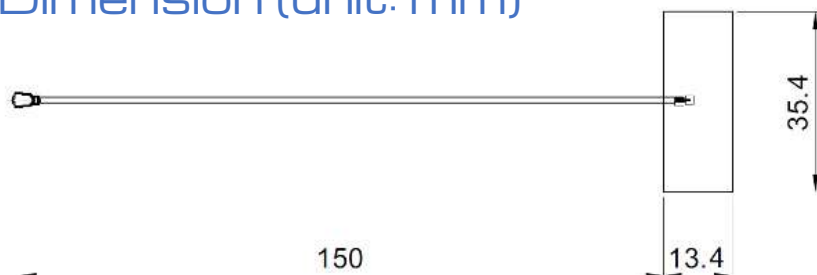

Embedded (Health Monitoring) Antenna

INTRODUCTION

MAEP103 is an ultra-small NFC antenna incorporating SkyMIRR's patented MulCAT® technology. It is suitable for cutting-edge devices such as biomedical micro-devices or wearable devices.

APPLICATION

- Mobile Micro Wearable devices (Smart watches, Earphones)
- Smart phone. Payment terminals
- Medical devices Human and animal implants (glass tubes), (Hearing aids)

Features and Benefits

- **Ferrite Core**
- **MulCAT® Technology Maximizes Magnetic Fields Easily Assembles to Device (Standard SMD device)**
- **Excellent Performance in Mobile, Medical Device and other IoT Wearable Devices**
- Antenna Size : 7.85 x 1.34 x 1.29mm
- Connector : Direct soldering on PCB (SMT)
- Operation Frequency Band – 13.56Mhz (NFC)
- RoHS Compliance



Performance

Specifications

Recognition distance	Inductance(uH)	DCR max.(ohm)
26mm	TBD	0.2 Ω
SRF(MHz)	Q value	Matching Value
TBD	TBD	TBD

VSWR

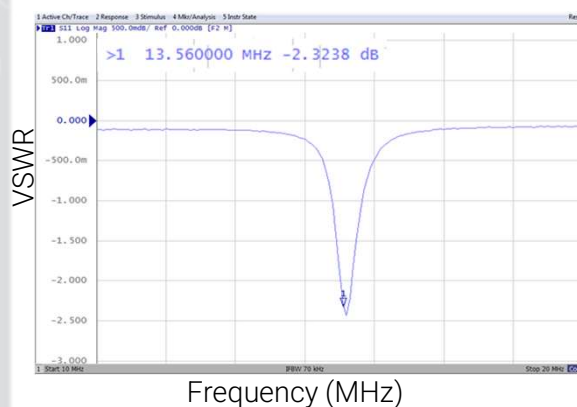

Dimension (unit: mm)

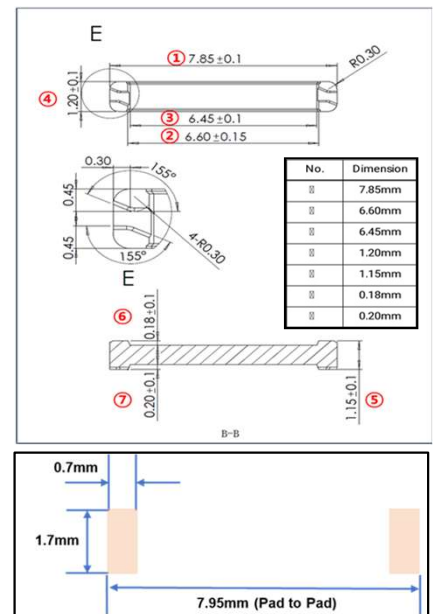

Contact Details:

US: +1-3213931039

TW: +886-963383713

KR: +82-1047149824

IN: +91-9967297130

Email: sales@skymirr.com

Website: www.skymirr.com

INTRODUCTION

The CGMP165 is a compact, high-performance GNSS antenna designed for reliable satellite signal reception across GPS and GLONASS bands. Built with a dielectric ceramic substrate and optimized for right-hand circular polarization, it delivers strong signal capture, low reflection loss and stable performance in space-constrained designs.

APPLICATIONS

This antenna is ideal for position and navigation applications where accuracy and consistency are critical. Typical use cases include asset tracking devices, automotive navigation systems, telematics units, drones and wearables.

Key Specifications

Embedded SMD Antenna Covering GPS and GLONASS bands

- Antenna Size: 25mm x 25mm x 4.0mm
- Frequency: 1575 MHz (GPS) and 1602 MHz (GLONASS)
- Impedance: 50 Ω
- Polarization: Right-hand circular
- Peak Gain: 3.3 dBi
- VSWR: ≤ 2.0



Materials

Constructed with a dielectric ceramic substrate and silver-plated electrodes, ground base, and feed point.

Operating Conditions

- Operating temperature range is -40°C to $+85^{\circ}\text{C}$
- storage temperature range is -40°C to $+110^{\circ}\text{C}$

Soldering and Handling

- Recommended peak reflow temperature is $210\pm 240^{\circ}\text{C}$ for 5-10 seconds.
- It is an electrostatic device and must be used within 24 hours of opening or be vacuum resealed.

Dimensions (unit: mm)

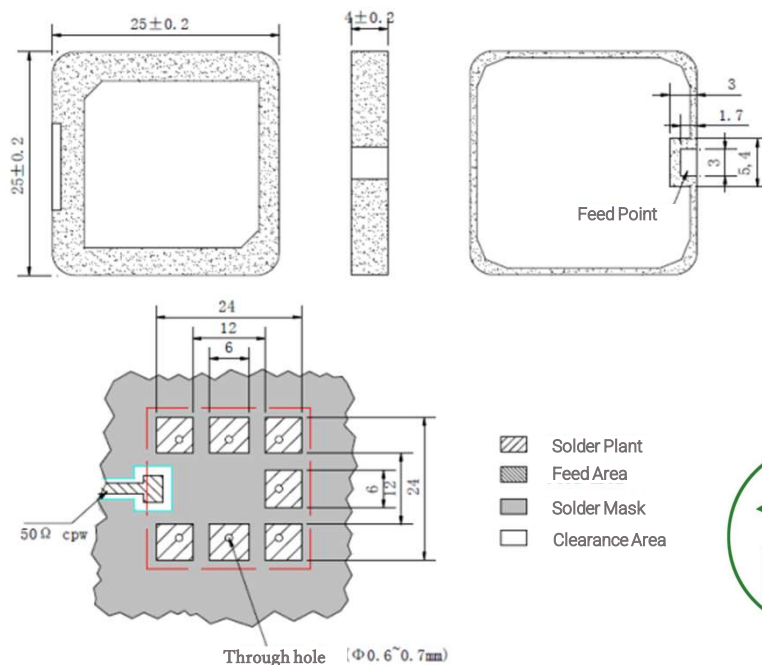

Contact Details:

US: +1-3213931039

TW: +886-963383713

KR: +82-1047149824

IN: +91-9967297130

Email: sales@skymirr.com

Website: www.skymirr.com



ITEMS	Specifications	
Frequency[Mhz]	1575.42 (GPS L1)	1602 (GLONASS G1)
Peak Axial Ratio (dB)	2.88	0.61
Typical Peak Gain (dBic)	3.14	3.36
VSWR	Less than 2 : 1	
Impedance	50Ω	
Polarization	RHCP	
Directivity	Directional	
Frequency Temperature Coefficient	0±10 ppm/°C	

VSWR



Frequency (MHz)

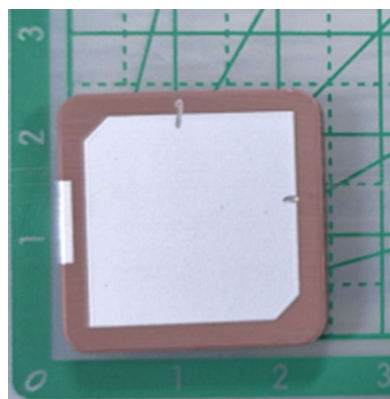
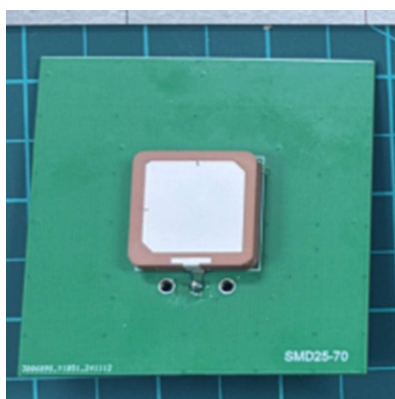

✳ EVB size : 70 x 70mm



Radiation Pattern

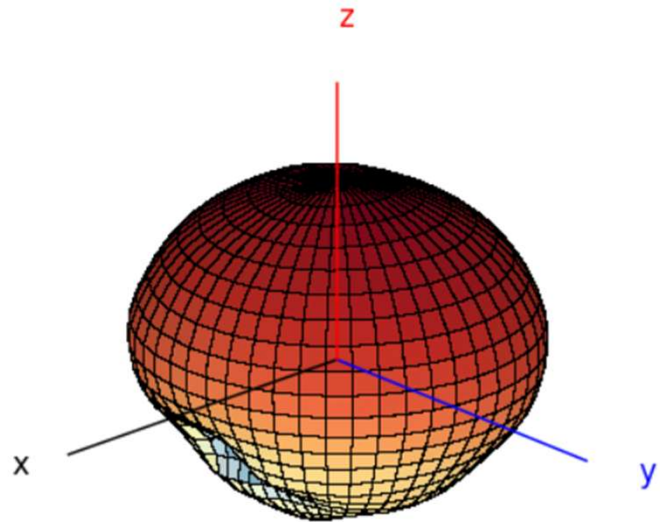
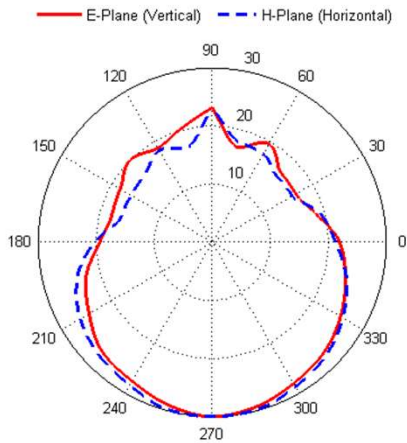

1575.42MHz

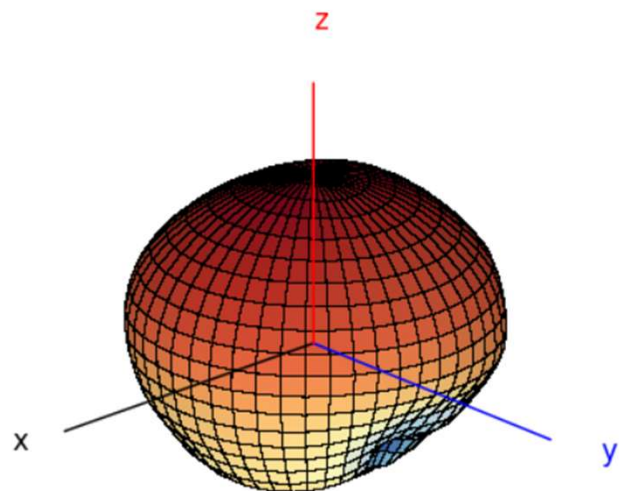
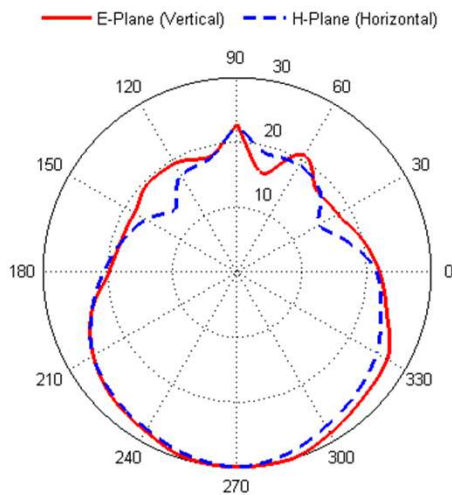

1602MHz



INTRODUCTION

This antenna is a compact **ceramic microstrip patch antenna** engineered for satellite navigation frequencies around **1575–1602 MHz** (GPS and GLONASS bands). It uses a **dielectric ceramic substrate** with a metallized patch and ground plane to create a highly efficient resonant structure in a very small form factor (18 × 18 × 4 mm).

APPLICATIONS

Because of its **small size, surface-mount capability, and stable performance across temperature and environmental conditions**, it is especially well-suited for **embedded systems** such as automotive trackers, drones, fleet management devices, and smart infrastructure. Its RHCP design ensures reliable satellite signal acquisition in real-world environments where orientation and multipath effects are common.

Contact Details:

US: +1-3213931039

TW: +886-963383713

KR: +82-1047149824

IN: +91-9967297130

Email: sales@skymirr.com

Website: www.skymirr.com

Key Specifications

- Antenna Size: 18mm x 18mm x 4.0mm
- Frequency: 1575 MHz (GPS) and 1602 MHz (GLONASS)
- Impedance: 50 Ω
- Polarization: Right-hand circular (RHCP)
- Peak Gain: 2.4 dBi
- VSWR: ≤2.0



Materials

Constructed with a dielectric ceramic element, pins are copper with tin plating. Silver-plated electrodes are situated at ground base, and feed point. Double-sided adhesive used us NITTO 5000NS

Operating Conditions

- Operating temperature range is -40°C to +85°C
- storage temperature range is -40°C to +110°C
- Relative Humidity range 55-75%RH
- Moisture Proof: exposure to 40 ± 2°C and 90-95% RH
- Vibration Resistance: Applied vibration of 10-55Hz(1.5MM amplitude) for 2 hours each in X,Y, and Z Directions

Soldering and Handling

- Adhesion strength of soldering: The antenna is tested to ensure it can withstand a force of 2kg applied to the lead in an axial direction for 10 ± 1 seconds.
- device must be used within 24 hours of opening or be vacuum resealed.

Dimensions (unit: mm)

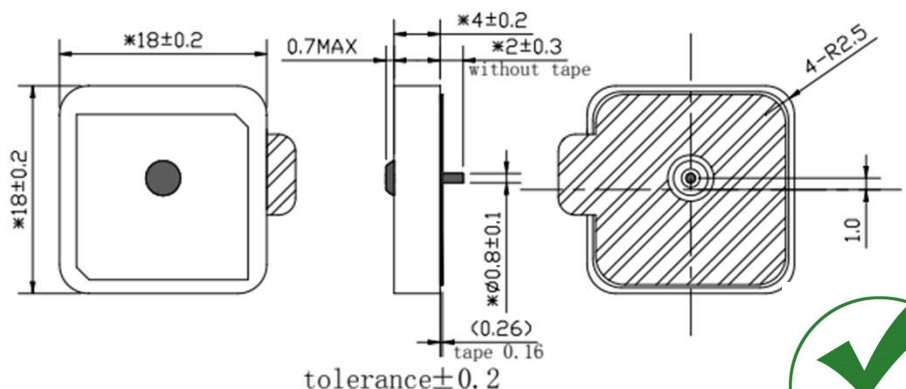

ITEMS	Specifications	
Frequency[Mhz]	1575.42 (GPS L1)	1602 (GLONASS G1)
Peak Axial Ratio (dB)	5.43	1.31
Typical Peak Gain (dBic)	1.68	2.40
VSWR	Less than 2 : 1	
Impedance	50Ω	
Polarization	RHCP	
Directivity	Directional	
Frequency Temperature Coefficient	0±10 ppm/°C	

VSWR

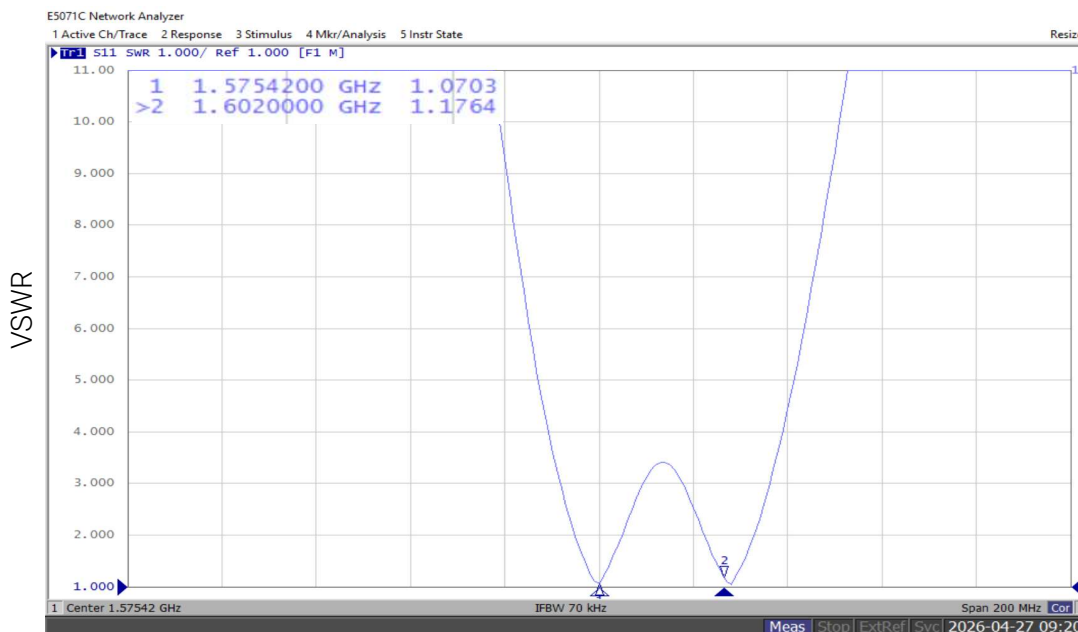

Frequency (MHz)

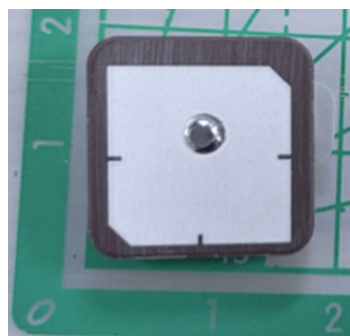
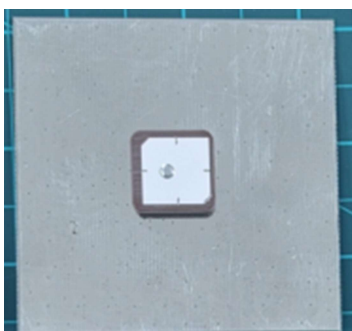

✳ EVB size : 70 x 70mm



Radiation Pattern

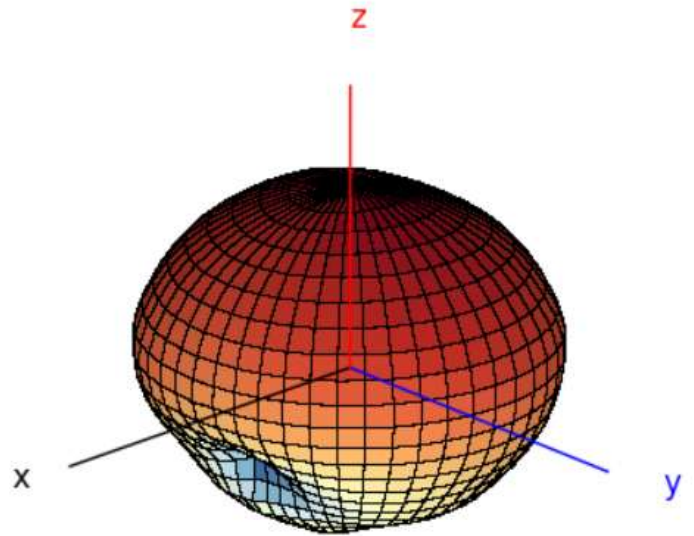
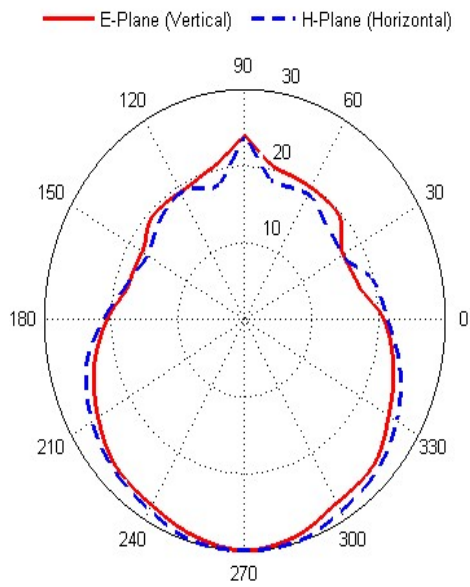

1575.42MHz

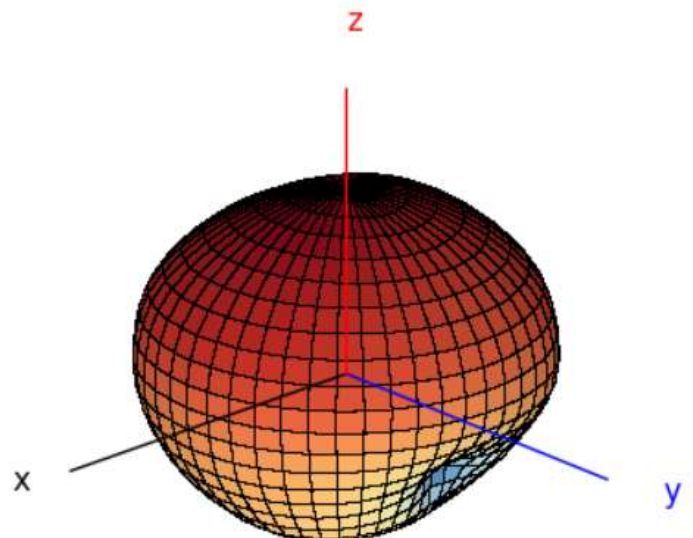
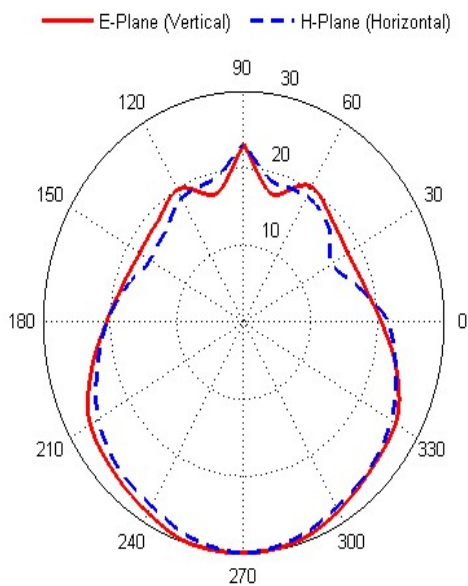

1602MHz



INTRODUCTION

The CGMP167 is a compact ceramic microstrip patch antenna engineered for applications operating at **1575–1602 MHz** (GPS and GLONASS bands).

It is well-suited for reliable satellite signal reception, even in environments with orientation variability or multipath interference.

APPLICATIONS

Its compact size, surface-mount design, and environmental durability (operating from -40°C to $+85^{\circ}\text{C}$) make it ideal for **industrial, automotive, and portable electronics** where space is limited but reliable satellite connectivity is critical.

Key Specifications

- Antenna Size: 25mm x 25mm x 4.0mm
- Frequency: 1575 MHz (GPS) and 1602 MHz (GLONASS)
- Center Frequency: 1583MHz (with JHSO2 ground plane)
- Impedance: 50 Ω
- Polarization: Right-hand circular (RHCP)
- Peak Gain: 3.5 dBi
- VSWR: <1.5



Materials

Antenna Substrate: Dielectric ceramics
 Pin: Copper and tin-plated alloy
 Electrode and Ground Base: silver-plated
 Adhesive: NITTO 5000NS

Operating Conditions

- Operating temperature range is -40°C to $+85^{\circ}\text{C}$
- storage temperature range is -40°C to $+110^{\circ}\text{C}$
- Relative Humidity range 55-75%RH
- Moisture Proof: exposure to $40 \pm 2^{\circ}\text{C}$ and 90-95% RH for 96 hours and 1-2 hours recovery time.
- Vibration Resistance: Applied vibration of 10-55Hz(1.5MM amplitude) for 2 hours each in X,Y, and Z Directions

Soldering and Handling

- Adhesion strength of soldering: The antenna is tested to ensure it can withstand a force of 2kg applied to the lead in an axial direction for 10 ± 1 seconds.
- device must be used within 24 hours of opening or be vacuum resealed.

Dimensions (unit: mm)

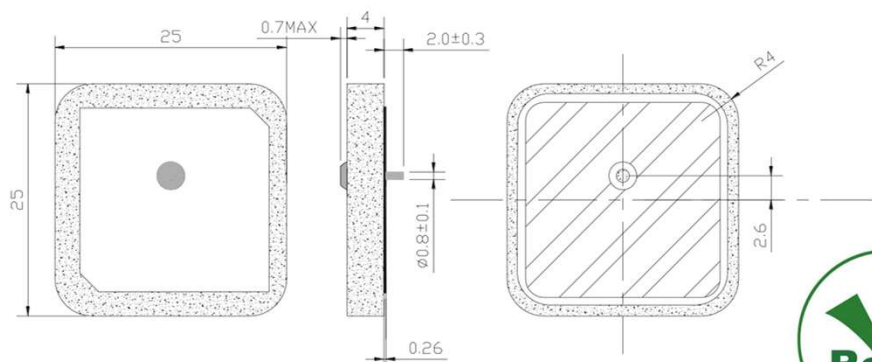

Contact Details:

US: +1-3213931039

TW: +886-963383713

KR: +82-1047149824

IN: +91-9967297130

Email: sales@skymirr.com

Website: www.skymirr.com



VSWR

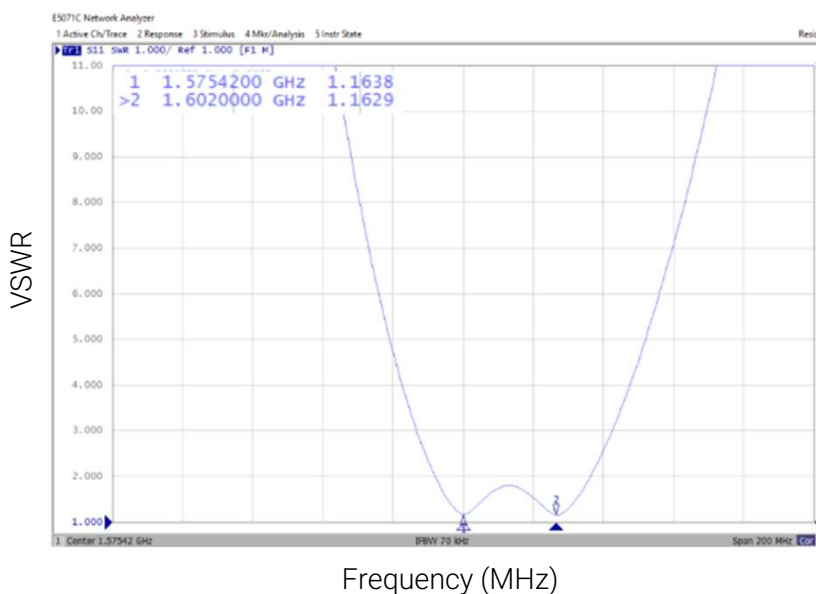

ITEMS	Specifications	
Frequency[Mhz]	1575.42 (GPS L1)	1602 (GLONASS G1)
Peak Axial Ratio (dB)	3.60	0.11
Typical Peak Gain (dBic)	3.17	3.58
VSWR	Less than 2 : 1	
Impedance	50Ω	
Polararization	RHCP	
Direcitivity	Directional	
Frequency Temperature Coefficient	0±10 ppm/°C	

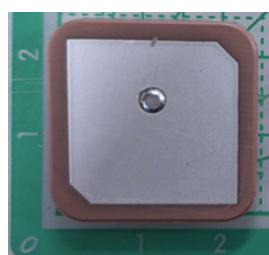
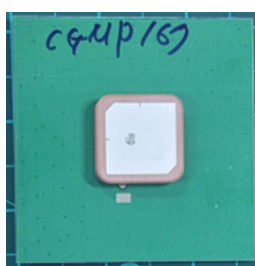

✳ EVB size : 70 x 70mm



Radiation Pattern

— E-Plane (Vertical) - - - H-Plane (Horizontal)

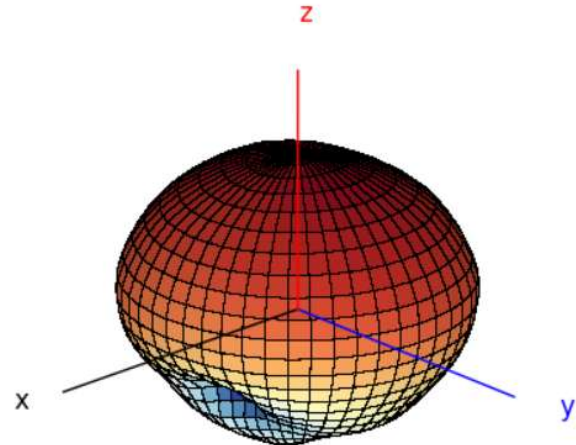
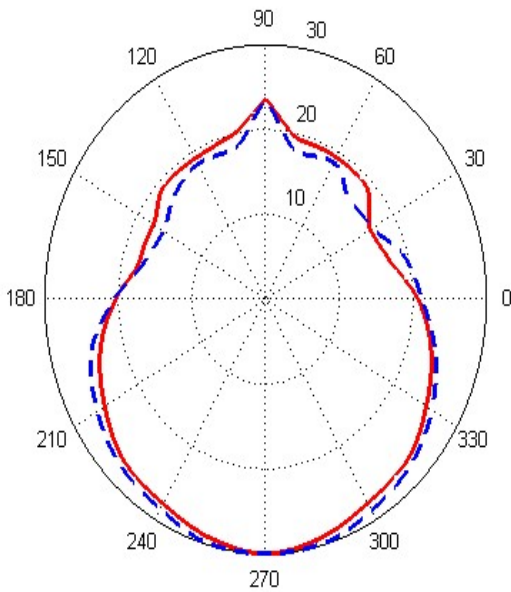

1575.42MHz

— E-Plane (Vertical) - - - H-Plane (Horizontal)

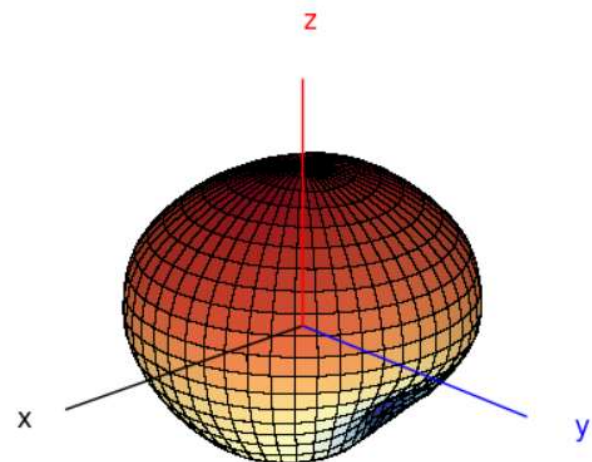
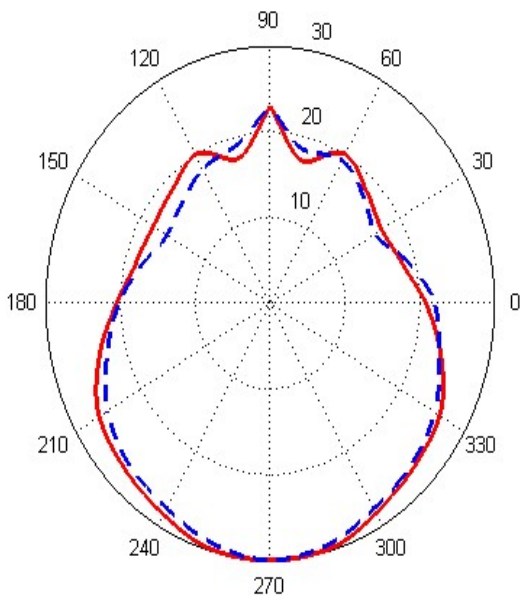

1602MHz



INTRODUCTION

CGMP168 is a compact, high-performance **multi-band GNSS patch antenna** engineered for precise positioning across multiple satellite constellations. Its **single-feed design and dual-stack architecture** enable wideband coverage (L1/L5 and beyond) while maintaining strong gain, low reflection loss, and stable axial ratio.

APPLICATIONS

This antenna is designed for **high-precision positioning and multi-constellation GNSS applications**.

Typical use cases include:
 Asset tracking and fleet management systems
 Navigation equipment and autonomous platforms (drones, robotics)
 Telematics and vehicle positioning systems
 Industrial IoT (M2M) devices requiring location awareness
 Surveying, mapping, and precision agriculture systems.

Contact Details:

US: +1-3213931039

TW: +886-963383713

KR: +82-1047149824

IN: +91-9967297130

Email: sales@skymirr.com

Website: www.skymirr.com

Key Specifications

- Antenna Size: 25mm x 25mm x 8.0mm
- Frequency Coverage: Covers Multiple bands including
- GPS (L1/L5)
- GLONASS (G1/G3)
- Galileo (E1/E5a)
- BeiDou(B1/B1C/B2a)
- QZSS (L1/L5)
- IRNSS (L5)

Frequency Ranges:

High Band: 1559-1592 MHz

Low Band: 1164-1189 MHz

- Impedance: 50 Ω
- Polarization: Right-hand circular (RHCP)

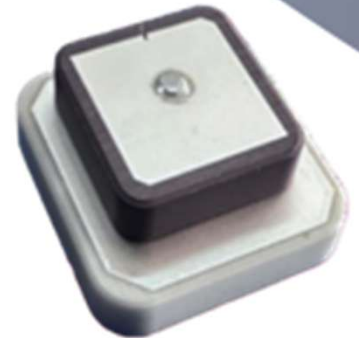

Materials

- Antenna Substrate: Dielectric ceramics
- Pin: Copper and tin-plated alloy
- Electrode and Ground Base: silver-plated
- Adhesive: NITTO 5000NS

Operating Conditions

- Operating temperature range is -40°C to +85°C
- Storage temperature range is -40°C to +85°C
- Vibration Resistance: Applied vibration of 10-55-5Hz(1.5CM amplitude) for 2 hours each in X,Y, and Z Directions

Soldering and Handling

- Must be soldered by hand within 3 seconds at a temperature of 390 \pm 20°C. Reflow soldering should not be used.
- Device must be used within 24 hours of opening or be vacuum resealed.

Dimensions (unit: mm)

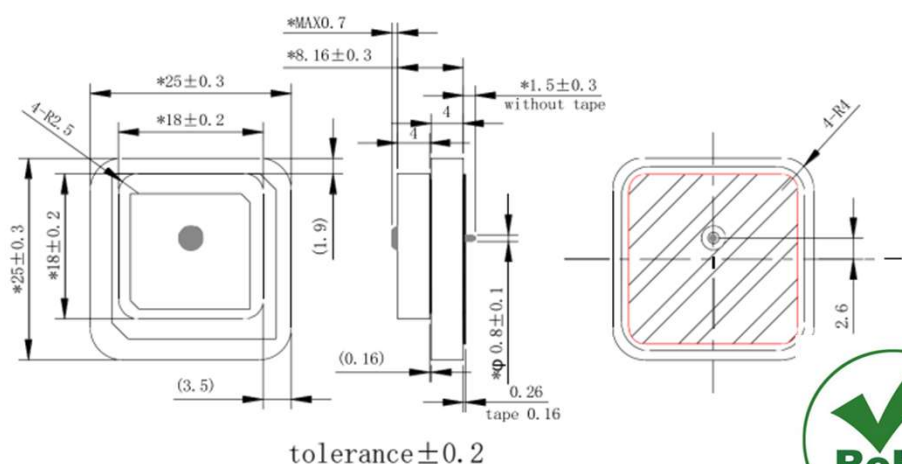

Bottom Patch Ant

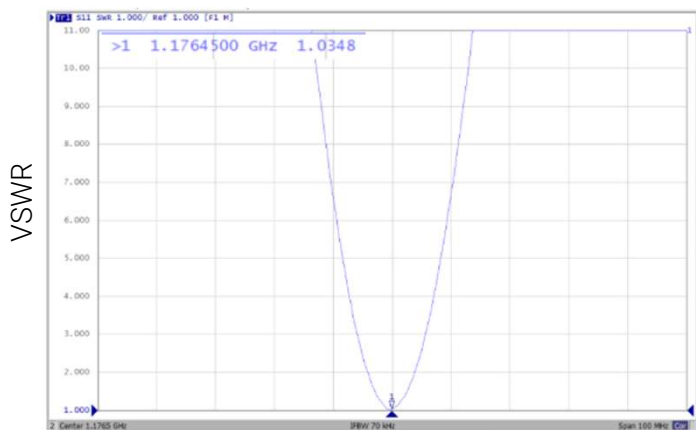

Frequency (MHz)

Top Patch Ant



Frequency (MHz)

ITEMS	Specifications		
Frequency[Mhz]	1176.45 (GPS L5)	1561.098 (Beidou B1I)	1575.42 (GPS L1)
Average Axial Ratio (dB)	3.44	7.82	5.67
Peak Axial Ratio (dB)	0.33	4.94	0.84
Typical Peak Gain (dBic)	2.01	3.76	3.82
VSWR	Less than 2 : 1		
Impedance	50Ω		
Polarization	RHCP		
Directivity	Directional		
Frequency Temperature Coefficient	0±10 ppm/°C		

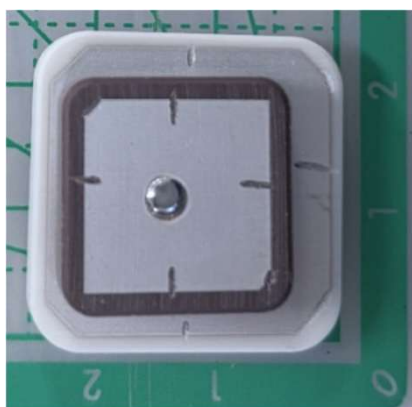

* EVB size : 70 x 70mm



Radiation Pattern

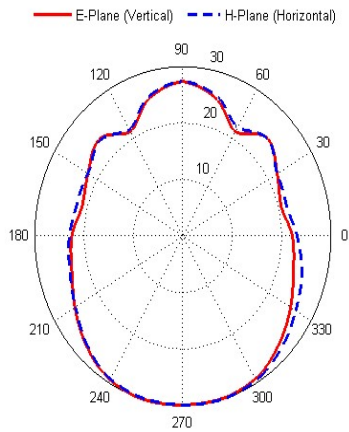

1176.45MHz

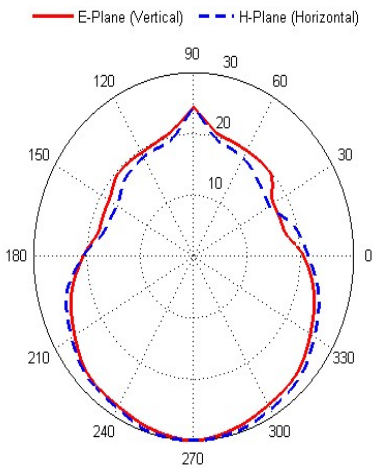
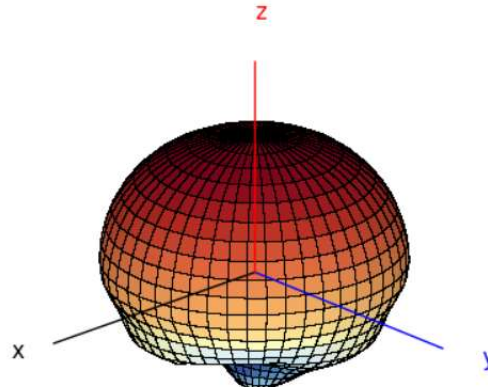

1561.098MHz

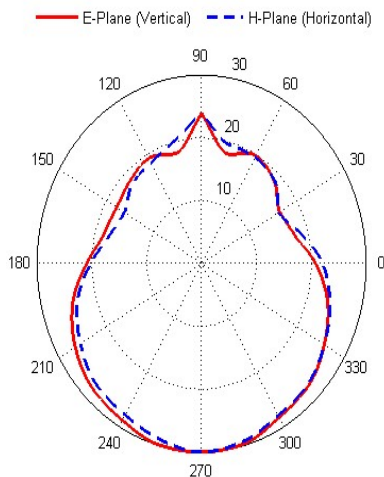
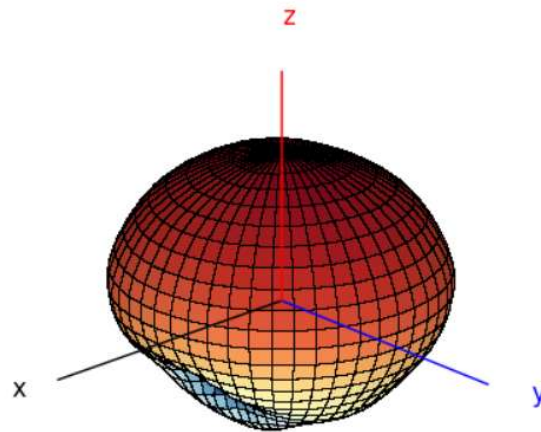

1575.42MHz

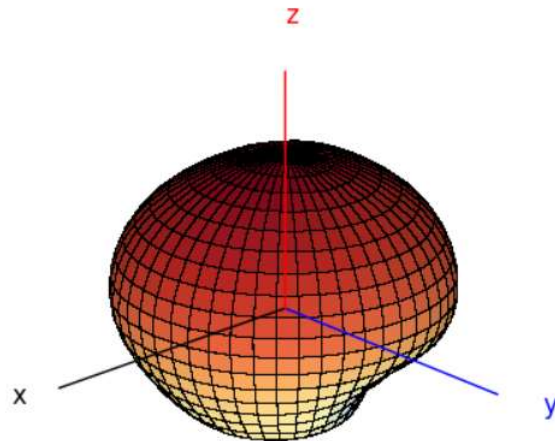

INTRODUCTION

The CGMA174 is a high-performance active GPS/GNSS magnetic-mount antenna engineered for precise positioning and reliable satellite signal reception. Operating across 1565–1605 MHz, it features RHCP polarization, a low-noise figure (<1.5), and an integrated LNA with 28 dB gain to enhance signal sensitivity. Its compact, rugged design and IP65–IP67-rated housing make it well-suited for demanding environments.

APPLICATIONS

The CGMA174 is ideal for navigation and positioning systems requiring accurate, stable satellite reception. Common applications include vehicle tracking, fleet management, asset tracking, telematics, and industrial IoT devices. Its magnetic mount and extended cable enable flexible placement on vehicles or equipment, ensuring optimal satellite visibility in both mobile and fixed installations.

Contact Details:

US: +1-3213931039

TW: +886-963383713

KR: +82-1047149824

IN: +91-9967297130

Email: sales@skymirr.com

Website: www.skymirr.com

Key Specifications

- Frequency Range: 1564.42-1605.89 MHz
- VSWR<1.5
- Impedance: 50 Ω
- Polarization: RHCP
- Axial Ratio: 3dB max
- LNA Gain: 28±2 dB
- Noise Figure:<1.5
- Supply Voltage: 3-5V DC
- Current Consumption: 5-15mA



Physical Characteristics

- Antenna Dimensions: 48.6 x 37.5 x 17mm
- Cable Length: RG174 3m
- Connector: SMA Male
- Installation: Magnet

Operating Conditions

- Operating temperature range: -40°C to +85°C
- Vibration Resistance: Applied vibration of 10-55Hz with 1.5mm amplitude for 2 hours
- Humidity: 5-95%
- Ingress Protection: IP64~IP67 (excluding cable outlet)

Dimensions (unit: mm)

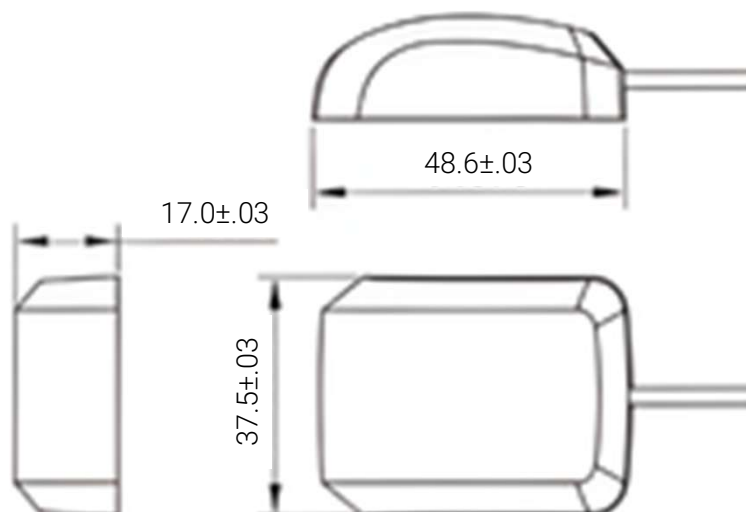

INTRODUCTION

The CGMA175 is a compact, high-sensitivity active GNSS antenna designed for reliable GPS and multi-constellation signal reception. With RHCP polarization, a low-noise amplifier delivering 28 dB gain, and excellent impedance matching (VSWR <1.5), it ensures consistent positioning performance even in challenging environments. Its rugged, screw-mount design supports stable integration into embedded and outdoor systems.

APPLICATIONS

The CGMA175 is ideal for precision positioning in both fixed and mobile deployments. It is commonly used in vehicle navigation, fleet and asset tracking, telematics systems, and industrial IoT devices. Its secure mounting and durable construction make it well-suited for outdoor equipment, smart infrastructure, and applications where reliable, continuous GNSS performance is critical.

Contact Details:

US: +1-3213931039

TW: +886-963383713

KR: +82-1047149824

IN: +91-9967297130

Email: sales@skymirr.com

Website: www.skymirr.com

Key Specifications

- Frequency Range: 1575.42±1/1601-1610
- VSWR<1.5
- Impedance: 50 Ω
- Polarization: RHCP
- Axial Ratio: 3dB max
- LNA Gain: 28±2dB
- Noise Figure: <1.5
- Supply Voltage: 3-5V DC
- Current Consumption: 5-15mA



Physical Characteristics

- Cable Length : RG174 3m
- Connector: SMA Male
- Antenna Dimensions: $\phi 46.6 \times 14.5$ mm
- Installation: Screw
- Ingress Protection: IP64~IP67 (excluding cable outlet)

Operating Conditions

- Operating temperature range: -40°C to +85°C
- Vibration Resistance: Applied vibration of 10-55Hz with 1.5mm amplitude for 2 hours
- Humidity: 5-95%
- Ingress Protection: IP64~IP67 (excluding cable outlet)

Dimensions (unit: mm)

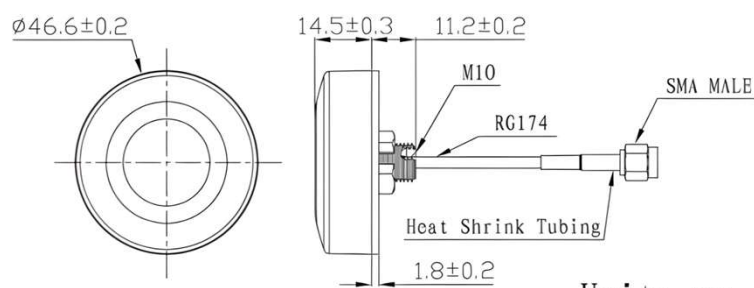

Unit: mm



INTRODUCTION

SkyMirr provides antenna customization service from antenna design/ sample delivery/ test/measurement/ pilot production to Mass production. SkyMirr customized antennas can perform best in the given form factor and environment.

APPLICATION

Any wireless/IoT device in any frequency band.

Features and Benefits

- Custom Designed Antenna for Any Wireless Device
- Antenna Size: Antennas can be designed in the form factor provided by the client.
- Connector: Any type including SMA, Spring, Pogo pin, Soldering, etc.
- Any Operation Frequency Band:
 - 4G LTE/ 5G Sub6
 - WiFi 5,6,7
 - GPS/GNSS
 - BT
 - NFC
 - 13.56Mhz (NFC)
- Best Performance in the given environment
- Short Design and Sample Delivery Leadtime

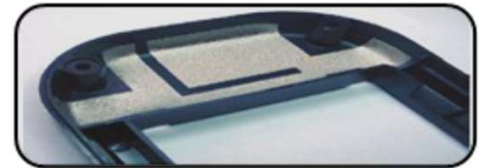

Customized Antenna Type

Stamped	Bare		Cabled Antennas	Printed on PCB	
	On Carrier			WiFi & WLAN	
Flex PCB	On Carrier		Retractable	DMV	
			NFC	FPC or Stamped Coil on Ferrite	
	On Housing	 <p>GPS Antenna Bluetooth Antenna Diversity Antenna Main Antenna</p>	Arrays	Smart Grid	
3D Plated	Double Injection Molding		Modules	Passive Modules (Speakers, Microphones, Sensors, etc)	
	LDS	  <p>LDS on Handset Housing</p>		Active Modules (Switch Tuning, RF FE, etc)	

Contact Details:

US: +1-3213931039

TW: +886-963383713

KR: +82-1047149824

IN: +91-9967297130

Email: sales@skymirr.com

Website: www.skymirr.com



SKYMIRR
BE AMAZED

ABOUT SKYMIRR

AI-DESIGNED WIRELESS IoT TECHNOLOGY

We provide revolutionary RF Technology and products for Wireless Terrestrial/Satellite Communication and Wireless Healthcare/Biomedical Applications.

Headquartered in Satellite Beach, Florida, SkyMirr, Inc. is the worldwide leader in designing, developing, manufacturing, and commercially shipping high performance RF/antenna/Wireless device solutions into wireless markets and applications where connectivity, low profile, and interference mitigation are paramount.

With revolutionary product designs in wireless healthcare/biomedical, terrestrial communications, and satellite communications markets, SkyMirr is pushing the boundary on some of the most challenging wireless connectivity problems in developing markets today.

R&D Capability in Place

- Initial R&D and product development capability is ready.
- Location: Incheon, Korea
- Equipment:
 - Full 3D anechoic test chamber
 - Network analyzers
 - Spectrum analyzers
 - Multi-meters and others
 - Work benches for prototyping



Core Competency with MuLCAT® Making Higher-Performing Antennas Smaller Than Previously Possible

SkyMirr's extensive knowledge and lengthy experience in electromagnetic theory design has resulted in its patent-pending Multi-layer Coupling Controlled Antenna Technology (MuLCAT®).

MuLCAT is specifically designed and is especially effective in applications where multiple antenna elements are co-located and confined in a small space, normally resulting in reduced performance due to mutual interference.

But with MuLCAT, this mutual coupling is now combined in a constructive way, improving performance such as frequency bandwidth, radiation efficiency, gain, and recognition distance significantly in a smaller confined space.

Mass Production-Locked And Loaded

- Contract Manufacturers IN PLACE in Vietnam and Korea
- Location: Bac Ninh, Vietnam / Incheon, Korea
- Entire SCM is ready including:
 - Plastic molding/tooling
 - Metal stamping
 - PCB
 - Cable/connectors
 - Final assembly and test
- Guaranteed low cost – efficient, well-trained line workers plus effective local supply chains
- High Quality – 100% inspection for all products that will be shipped
- Training already completed
- Every product we ship is guaranteed
- RMA system to react to any potential quality issue in customers ASAP.



SKYMIRR
BE AMAZED

ABOUT SKYMIRR

DESIGN SERVICES

If you would like SkyMirr to look at creating a customized antenna solution for your product using its proprietary MULCAT(r) technology, please contact us for a quotation.

PRODUCTS AND APPLICATIONS

SkyMirr Broadband Access Products And Applications

Several broadband access products for various environments are in development to insure continuing revenue growth

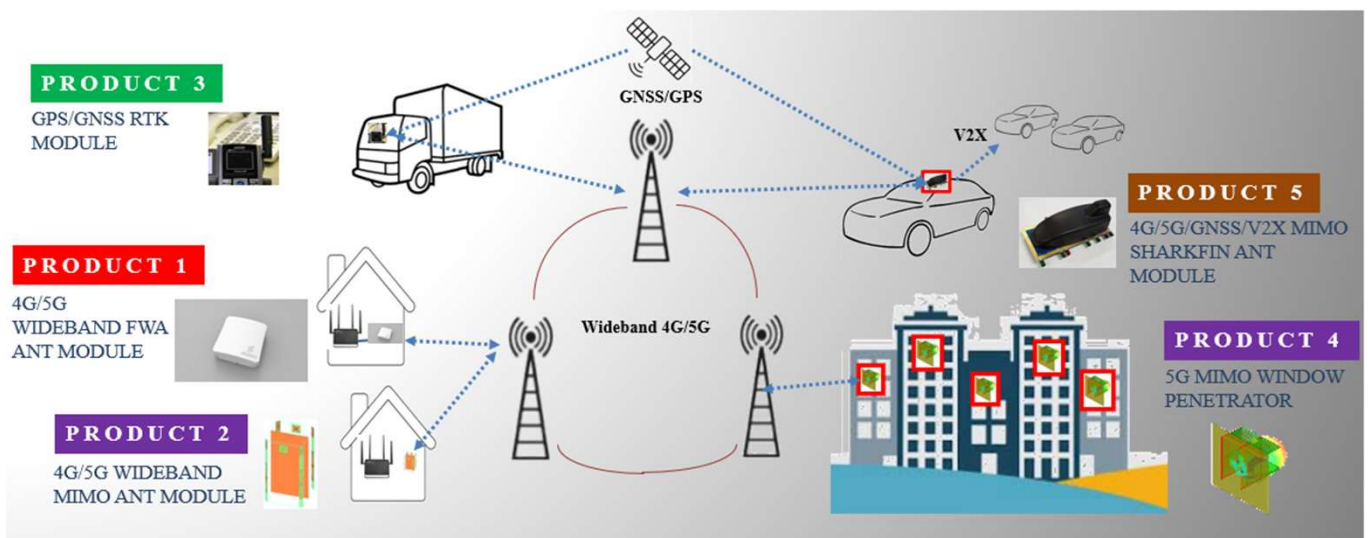



SKYMIRR

BE AMAZED

321-393-1039

930 S. Harbor City Blvd
Suite 403
Melbourne, FL 32901

sales@skymirr.com

www.skymirr.com